

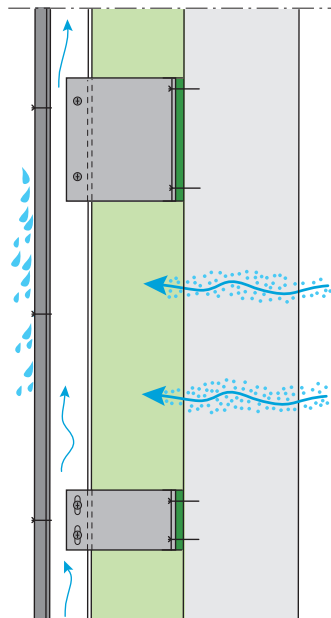

WELL-INSULATED VENTILATED FACADES

PAROC DESIGN GUIDE



PAROC[®]

CONTENT

1. Well-insulated ventilated facades

1.1. General design guidelines	4
--------------------------------------	---

2. Design principles for ventilation

2.1. Dimensioning of the ventilation	6
2.2. Design of thermal insulation	14

3. PAROC products.....	19
------------------------	----

4. PAROC insulation solutions

4.1. Timber frame constructions.....	22
4.2. CLT constructions with PAROC ZEROfix-mounting system ..	24
4.3. Metal frame facade systems	26
4.4. Masonry/Construction examle	28
4.5. PAROC ZEROfix-mounting system	31

1. WELL-INSULATED VENTILATED FACADES

Ventilated facade is a general term for facade structures in which there is a uniform ventilation gap between the facade cladding and the thermal insulation layer, which improves the moisture safety of the structure. In these structures, the actual facade cladding is suspended from the load-bearing construction (supporting substrate) through the thermal insulation layer. The ventilation gap is connected to the outside air via air-supply openings at the bottom edge and exhaust openings at the top edge of the wall or wall sections (e.g., additional ventilation openings per floor connected to window and door openings), which ensures continuous natural air exchange.

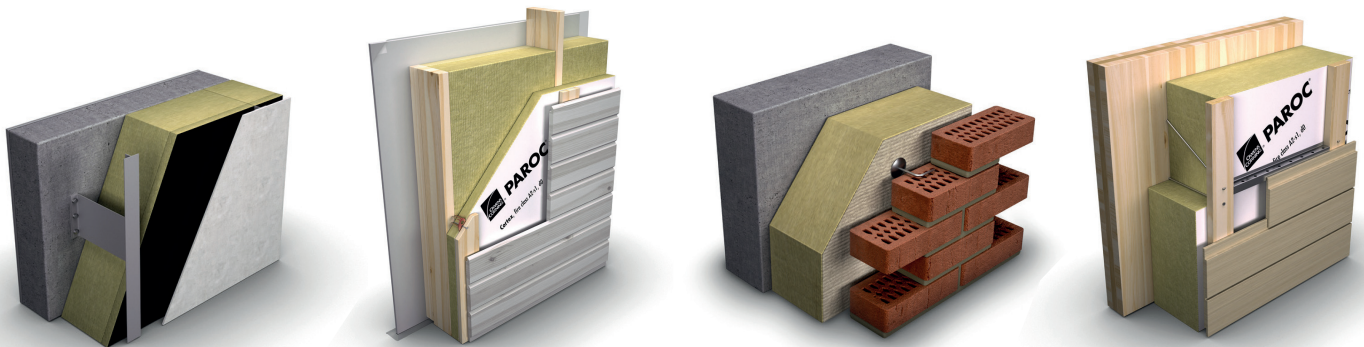

Ventilated facades are characterized by many different system components from different vendors. This can make it difficult for the designer to achieve all the goals set for the structure. In many cases, the design of a facade begins with the choice of facade cladding, after which the structure that supports it is considered, and only finally is the insulation material suitable for the system selected.

Although the insulation entering the structure is at the end of the selection list, it and its functionality play an important role in the thermal, fire, and moisture performance of the building envelope.

The objective of this design guide is to present guidelines for PAROC thermal insulation products when applied in ventilated walls of new buildings. These walls can be built using concrete, aerated concrete blocks, brick, wood frame, or CLT as the load-bearing structure.

These guidelines were determined using numerical simulations and analyses performed by VTT (Research report VTT-R-01215-20). Recommended values presented in dimensioning tables are mostly based on yearly average moisture load and wind conditions in different climate zones. Several boundaries were set based on expert opinion to study the defined cases of wall ventilation considering the project plan and scale. The results can't be considered as exact limit values, but they give good approximations on how to realize wall ventilation having adequate moisture drying efficiency with reasonable convection effects on thermal performance.

Three typical European climates were used in the studies:

	Northern climate Vantaa, Finland	Coastal mild climate Bergen, Norway	Central European climate Holzkirchen, Germany
T, average (°C)	6,5	8,1	6,6
T, min. (°C)	-24,8	-9,7	-20,1
V, wind, average (m/s)	4,4	3,4	2,3
Precipitation yearly (mm)	756	2421	1185

1.1. GENERAL DESIGN GUIDELINES

A ventilated facade can be designed either for new buildings or retrofit of existing buildings. It is important to check the general and local building regulations, especially in the area of structural, thermal, fire, and sound performance set for the materials, load bearing structures, or building envelope.

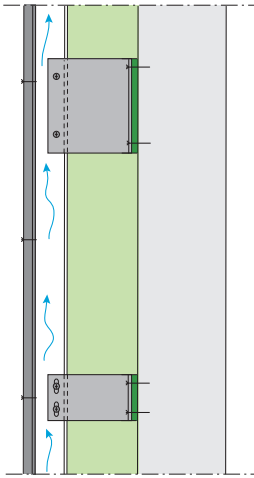

Advantages of ventilated facade:

- External cladding with the ventilation gap gives the structure long-term weather and moisture safety
- Well-chosen suspension system and insulation materials allow almost any desired U-value to be achieved.
- Simple solutions for facade renovations thanks to adjustable substructures
- Sustainable construction due to long service life, low maintenance costs and separate recyclable layers
- Fire protection through appropriate choice of non-combustible components and building materials

Moisture safety

Moisture control is fundamental to the proper functioning of any building. Well-designed building envelope protects its occupants from adverse health effects and the building from damages.

Most of the structural moisture problems in buildings are caused by ground moisture, rain, or water used inside the building. Moisture control is an essential part of the building design phase; luckily, the design rules are rather simple:

- Make sure that moisture does not get inside the structures and
- Ensure with material choices that the moisture inside the structure can dry

Adequate wall ventilation air-flow rates are needed for the good moisture performance of ventilated walls. This alone doesn't guarantee the safe performance. Several other factors (diffusion resistances of the material layers, climate loads, air leakages, etc.) may affect the moisture performance that has to be ensured separately.

The facade material doesn't only play a visual role in the building envelope – it works as a raincoat and weather protection for inner material layers of a wall structure. The facade cladding and the substructure of the facade must be planned and designed in such a way that penetrating rainwater and any possible condensation moisture that may form can be removed to the outside from the construction in a controlled manner. This is to prevent moisture from penetrating into the thermal insulation or the supporting substrate frame or into any wooden parts of the substructure.

The design of joints between panels, sheets, or boards used for facade cladding in ventilated facades is important, and their sealing of the joints must be done properly. Even if the ventilation gap may have the capacity to convey water penetration away to the exterior, the material forming the cladding may become very wet, compromising its appearance and durability. In climate zones with freezing rain events, ice formation may induce stresses and deform the cladding, which can lead to other damages.

Constructive moisture protection, e.g., flashings, are needed to manage rainwater on facade surfaces, because most buildings have transitions between materials, assemblies, and components that represent either discontinuities and/or changes of the geometry in the water-resistive barrier and drainage space.

In an external wall structure, the densest material layers are always placed on the inner surface of the wall structure. The water vapor permeability of the material layers should increase when moving outward in the structure so that the structural moisture can dry outward. In ventilated facades, drying happens via the ventilation gap, meaning that facade material can be vapor tight

Fire safety

Fire spread through the facades is widely recognized as one of the fastest pathways of fire spreading in buildings. Room fire may spread through the facade in different ways, depending on the type of facade system and materials from which it is constructed. Ventilating facades are multilayer systems whose main feature is the creation of an air chamber of

circulating air between the building wall and the external cladding. The "chimney effect" in the air gap is a mechanism that improves the facade's thermal and moisture behavior. However, in the event of a fire, it may contribute to the quickest route for fire spreading, representing a significant risk to the upper floors of a building. Therefore, it is always recommended to use non-combustible insulation and facade materials in ventilated facade systems.

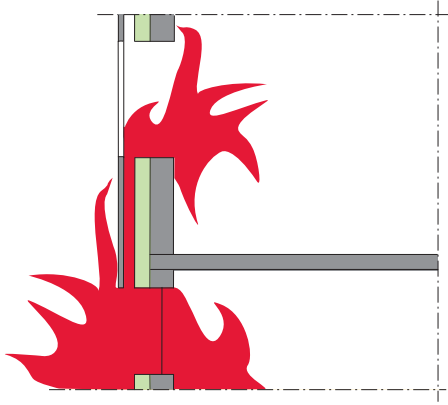

"Chimney effect" of exterior cladding

Energy efficiency

The choice of facade material can have a significant effect on the energy efficiency of ventilated facades, as, for example, in metal profile systems, the weight and fastening of the actual facade layer imposes requirements on the underlying frame structure and the cold bridges coming through the insulation layer.

Mechanical stability

Ventilated facade cladding is connected mechanically to the load-bearing structure, and it must be stable in all the conditions. Dimensioning of the fasteners of the system is generally done by a structural engineer or a metal frame system manufacturer. In this context, the following loads (as applicable) must be considered:

- dead load
- wind load (suction and pressure)
- snow and ice loads
- impact loads
- special loads (e.g., seismic forces, advertising boards)

An itemized structural engineer's report of the ventilated facade system must be prepared in compliance with the pertinent European and/or national regulations. This proof of stability must be provided in a verifiable form and contain the stability calculations for the substructure, the cladding, the primary fixing elements, and the securing elements. For metal frame systems these calculations are usually provided by metal frame system manufacturer based on parameters given by structural engineer.

2. DESIGN PRINCIPLES FOR VENTILATION

2.1. DIMENSIONING OF THE VENTILATION

In a ventilated facade, outdoor air-flows through the openings into the ventilation gap, where it warms up due to the heat losses through the wall and solar radiation. Degree of warming depends on the U-value of the structure and on the moisture performance of the facade. High moisture content of the facade decreases the thermal resistance, and the evaporating moisture decreases the temperature difference needed in effective ventilation. Typically, the yearly average temperature difference between the ventilation air and the outdoor air is in the range of 0,2–0,6 °C.

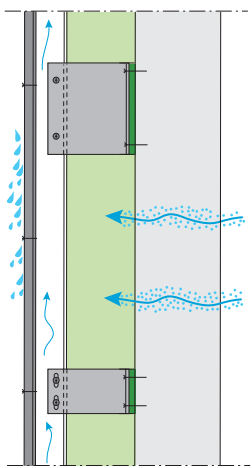

Facade ventilation is needed to dry out the additional moisture from the external wall structure. The typical moisture sources are initial building moisture, moisture loads from indoor and outdoor (ventilation) air and the wetting of the facade due to wind-driven rain. The challenge is to provide sufficient ventilation for walls under different climate conditions causing varying loads and wind pressures. Also building heights, cavity dimensions, structural details and the possible fire breaks in the cavity needs to be considered.

The following dimensioning tables for different kinds of wall structures are based on numerical simulations done by VTT, by using the WUFI® 6.1 -model applied to a large set of following combinations of different structural elements:

- Load-bearing materials: concrete, aerated concrete, brick, wood frame, or CLT
- Facade materials: Timber (28 mm), brick (130 mm), cement fiber board (8 mm)
- Thermal insulation: Stone wool having thicknesses 200 mm, 250 mm or 300 mm, depending on the actual wall material and its dimensions
- Initial moisture content of the wall material (concrete, aerated concrete, brick)

The thicknesses were set to be high to have the worst-case scenario for the moisture performance: high moisture capacity and low temperature differences between ventilation and outdoor air.

Three- to five-year simulation periods were used in the analysis, depending on how fast the initial moisture could be dried out. The outdoor climate was from the WUFI model library (Vantaa, Bergen, and Holzkirchen), and the indoor climate had +20 °C temperature with level 2 moisture loads (maximum +4 g/m³ increase of moisture compared to outdoor air). Only in the wood frame structure was there a vapor barrier ($S_d = 50$ m).

Average pressure differences for the different building heights were evaluated based on the climate data for the studied locations. These pressure differences were used as driving forces for the ventilation. When the height of the building increases, the needed air-flow rate increases and the required pressure difference to support the air-flow rate increases exponentially. Natural convection induced by temperature difference was also considered when necessary.

The driving rain was considered in the simulations. The wall structures were facing the highest driving rain direction, typically south or south-west. The studied part of the wall was the top section of a high (> 25 m) building that has the highest-driving rain loads. Solar radiation was omitted in the simulations and the analysis includes safety.

The highest moisture loads into ventilation space were detected when using a 130 mm thick brick facade. The load with brick facade was not dependent on the inner wall structure. There was no surface coating/treatment preventing the brick from wetting due to driving rain. The results could differ significantly from the presented if the facade brick layer was thinner having lower moisture capacity, or if the facade was protected against wetting by (hydrophobic) treatment.

Timber & metal frame walls (Northern climate; Vantaa, Finland)

Initial moisture content of the structure max 80% (RH equilibrium)

Building height and facade material									
		2 floors ≤ 7 m		4–5 floors ≤ 14–18 m		8–9 floors ≤ 28–32 m		16 floors ≤ 56 m	
		Wood or cement fiber board	Brick	Wood or cement fiber board	Brick	Wood or cement fiber board	Brick	Wood or cement fiber board	Brick
Needed air-flow rate in ventilation gap, in ventilation gap, yearly average, dm ³ /s m ²		0,022	0,33	0,022	0,33	0,022	0,33	0,022	0,33
Needed air-flow rate in ventilation gap with different building heights (dm ³ /s m ²) per wall width (e.g. 7 x 0,022 = 0,154 dm ³ /s m)		0,154	2,31	0,396	5,94	0,704	10,56	1,232	18,48
Dimensioning of ventilation openings (mm ² /m) leading air to ventilation gap to reach the needed ventilation rate									
Width of ventilation gap	45 mm	110	1450	220	2800	370	4600	580	8600
	25 mm	100	1500	230	3000	380	5900	600	-
	45 mm + Fire barrier	210	1800	500	-	1850	-	-	-
	25 mm + Fire barrier	220	-	720	-	-	-	-	-
Required air permeability / air-flow resistivity for insulation layer to avoid convection:		≤ 30 x 10 ⁻⁶ m ³ /m s Pa		≤ 40 x 10 ⁻⁶ m ³ /m s Pa		≤ 40 x 10 ⁻⁶ m ³ /m s Pa ≤ 30 x 10 ⁻⁶ m ³ /m s Pa, in case of additional openings (e.g window openings)			
It is always good to use lower air permeability than required. With fire barriers it is recommended to use more air tight wind protection insulation with membrane ≤ 10 x 10 ⁻⁶ m ³ /m ² s Pa									

Note: facade material in these instructions can be replaced with less water absorbing materials e.g. glass, metal, etc.

CLT walls (Northern climate; Vantaa, Finland)

Initial moisture content of the structure max 67% (RH equilibrium)

Building height and facade material									
		2 floors ≤ 7 m		4–5 floors ≤ 14–18 m		8–9 floors ≤ 28–32 m		16 floors ≤ 56 m	
		Wood or cement fiber board	Brick	Wood or cement fiber board	Brick	Wood or cement fiber board	Brick	Wood or cement fiber board	Brick
Needed air-flow rate in ventilation gap, in ventilation gap, yearly average, dm ³ /s m ²		0,045	0,33	0,045	0,33	0,045	0,33	0,045	0,33
Needed air-flow rate in ventilation gap with different building heights (dm ³ /s m ²) per wall width (e.g. 7 x 0,045 = 0,315 dm ³ /s m)		0,315	2,31	0,810	5,94	1,440	10,56	2,520	18,48
Dimensioning of ventilation openings (mm ² /m) leading air to ventilation gap to reach the needed ventilation rate									
Width of ventilation gap	45 mm	180	1450	400	2800	660	4600	1030	8600
	25 mm	180	1500	410	3000	670	5900	1100	-
	45 mm + Fire barrier	210	1800	500	-	1850	-	-	-
	25 mm + Fire barrier	220	-	720	-	-	-	-	-
Required air permeability / air-flow resistivity for insulation layer to avoid convection:		≤ 30 x 10 ⁻⁶ m ³ /m s Pa		≤ 40 x 10 ⁻⁶ m ³ /m s Pa		≤ 40 x 10 ⁻⁶ m ³ /m s Pa ≤ 30 x 10 ⁻⁶ m ³ /m s Pa, in case of additional openings (e.g window openings)			
It is always good to use lower air permeability than required. With fire barriers it is recommended to use more air tight wind protection insulation with membrane ≤ 10 x 10 ⁻⁶ m ³ /m ² s Pa									

Note: facade material in these instructions can be replaced with less water absorbing materials e.g. glass, metal, etc.

Concrete, aerated concrete block and brick walls (Northern climate; Vantaa, Finland)

Initial moisture content of the structure: Concrete max. 95% Aerated concrete or brick max. 85% (RH equilibrium)

Building height and facade material									
		2 floors ≤ 7 m		4–5 floors ≤ 14–18 m		8–9 floors ≤ 28–32 m		16 floors ≤ 56 m	
		Wood or cement fiber board	Brick	Wood or cement fiber board	Brick	Wood or cement fiber board	Brick	Wood or cement fiber board	Brick
Needed air-flow rate in ventilation gap, in ventilation gap, yearly average, dm ³ /s m ²		0,056	0,28	0,056	0,28	0,056	0,28	0,056	0,28
Needed air-flow rate in ventilation gap with different building heights (dm ³ /s m ²) per wall width (e.g. 7 x 0,056 = 0,392 dm ³ /s m)		0,392	1,96	1,008	5,04	1,792	8,96	3,136	15,68
Dimensioning of ventilation openings (mm ² /m) leading air to ventilation gap to reach the needed ventilation rate									
Width of ventilation gap	45 mm	250	1450	550	2800	920	4600	1460	8600
	25 mm	260	1500	560	3000	950	5900	1600	-
	45 mm + Fire barrier	210	1800	500	-	1850	-	-	-
	25 mm + Fire barrier	220	-	720	-	-	-	-	-
Required air permeability / air-flow resistivity for insulation layer to avoid convection:		≤ 30 x 10 ⁻⁶ m ³ /m s Pa		≤ 40 x 10 ⁻⁶ m ³ /m s Pa		≤ 40 x 10 ⁻⁶ m ³ /m s Pa ≤ 30 x 10 ⁻⁶ m ³ /m s Pa, in case of additional openings (e.g window openings)			
It is always good to use lower air permeability than required. With fire barriers it is recommended to use more air tight wind protection insulation with membrane ≤ 10 x 10 ⁻⁶ m ³ /m ² s Pa									

Note: facade material in these instructions can be replaced with less water absorbing materials e.g. glass, metal, etc.

Timber & metal frame walls (Coastal mild climate; Bergen, Norway)

Initial moisture content of the structure max 80% (RH equilibrium)

Building height and facade material									
		2 floors ≤ 7 m		4–5 floors ≤ 14–18 m		8–9 floors ≤ 28–32 m		16 floors ≤ 56 m	
		Wood or cement fiber board	Brick	Wood or cement fiber board	Brick	Wood or cement fiber board	Brick	Wood or cement fiber board	Brick
Needed air-flow rate in ventilation gap, in ventilation gap, yearly average, dm ³ /s m ²		0,028	0,44	0,028	0,44	0,028	0,44	0,028	0,44
Needed air-flow rate in ventilation gap with different building heights (dm ³ /s m ²) per wall width (e.g. 7 x 0,028 = 0,196 dm ³ /s m)		0,196	3,08	0,504	7,920	0,896	14,08	1,568	24,64
Dimensioning of ventilation openings (mm ² /m) leading air to ventilation gap to reach the needed ventilation rate									
Width of ventilation gap	45 mm	160	5500	350	-	560	-	910	-
	25 mm	160	-	350	-	570	-	970	-
	45 mm + Fire barrier	320	-	900	-	-	-	-	-
	25 mm + Fire barrier	330	-	10000	-	-	-	-	-
Required air permeability / air-flow resistivity for insulation layer to avoid convection:		≤ 30 x 10 ⁻⁶ m ³ /m s Pa		≤ 40 x 10 ⁻⁶ m ³ /m s Pa		≤ 40 x 10 ⁻⁶ m ³ /m s Pa ≤ 30 x 10 ⁻⁶ m ³ /m s Pa, in case of additional openings (e.g window openings)			
It is always good to use lower air permeability than required. With fire barriers it is recommended to use more air tight wind protection insulation with membrane ≤ 10 x 10 ⁻⁶ m ³ /m ² s Pa									

Note: facade material in these instructions can be replaced with less water absorbing materials e.g. glass, metal, etc.

CLT walls (Coastal mild climate; Bergen, Norway)

Initial moisture content of the structure max 67% (RH equilibrium)

Building height and facade material									
		2 floors ≤ 7 m		4–5 floors ≤ 14–18 m		8–9 floors ≤ 28–32 m		16 floors ≤ 56 m	
		Wood or cement fiber board	Brick	Wood or cement fiber board	Brick	Wood or cement fiber board	Brick	Wood or cement fiber board	Brick
Needed air-flow rate in ventilation gap, in ventilation gap, yearly average, dm ³ /s m ²		0,057	0,44	0,057	0,44	0,057	0,44	0,057	0,44
Needed air-flow rate in ventilation gap with different building heights (dm ³ /s m ²) per wall width (e.g. 7 x 0,057 = 0,399 dm ³ /s m)		0,399	3,08	1,026	7,92	1,824	14,08	3,192	24,64
Dimensioning of ventilation openings (mm ² /m) leading air to ventilation gap to reach the needed ventilation rate									
Width of ventilation gap	45 mm	270	5500	590	-	950	-	1550	-
	25 mm	270	-	600	-	990	-	1740	-
	45 mm + Fire barrier	320	-	900	-	-	-	-	-
	25 mm + Fire barrier	330	-	10000	-	-	-	-	-
Required air permeability / air-flow resistivity for insulation layer to avoid convection:		≤ 30 x 10 ⁻⁶ m ³ /m s Pa		≤ 40 x 10 ⁻⁶ m ³ /m s Pa		≤ 40 x 10 ⁻⁶ m ³ /m s Pa ≤ 30 x 10 ⁻⁶ m ³ /m s Pa, in case of additional openings (e.g window openings)			
It is always good to use lower air permeability than required. With fire barriers it is recommended to use more air tight wind protection insulation with membrane ≤ 10 x 10 ⁻⁶ m ³ /m ² s Pa									

Note: facade material in these instructions can be replaced with less water absorbing materials e.g. glass, metal, etc.

Concrete, aerated concrete block and brick walls (Coastal mild climate; Bergen, Norway)

Initial moisture content of the structure: Concrete max. 95% Aerated concrete or brick max. 85% (RH equilibrium)

Building height and facade material									
		2 floors ≤ 7 m		4–5 floors ≤ 14–18 m		8–9 floors ≤ 28–32 m		16 floors ≤ 56 m	
		Wood or cement fiber board	Brick	Wood or cement fiber board	Brick	Wood or cement fiber board	Brick	Wood or cement fiber board	Brick
Needed air-flow rate in ventilation gap, in ventilation gap, yearly average, dm ³ /s m ²		0,078	0,39	0,078	0,39	0,078	0,39	0,078	0,39
Needed air-flow rate in ventilation gap with different building heights (dm ³ /s m ²) per wall width (e.g. 7 x 0,078 = 0,546 dm ³ /s m)		0,546	2,73	1,404	7,02	2,496	12,48	4,368	21,84
Dimensioning of ventilation openings (mm ² /m) leading air to ventilation gap to reach the needed ventilation rate									
Width of ventilation gap	45 mm	420	5500	900	-	1460	-	2420	-
	25 mm	420	-	920	-	1550	-	2970	-
	45 mm + Fire barrier	320	-	900	-	-	-	-	-
	25 mm + Fire barrier	330	-	10000	-	-	-	-	-
Required air permeability / air-flow resistivity for insulation layer to avoid convection:		≤ 30 x 10 ⁻⁶ m ³ /m s Pa		≤ 40 x 10 ⁻⁶ m ³ /m s Pa		≤ 40 x 10 ⁻⁶ m ³ /m s Pa ≤ 30 x 10 ⁻⁶ m ³ /m s Pa, in case of additional openings (e.g window openings)			
It is always good to use lower air permeability than required. With fire barriers it is recommended to use more air tight wind protection insulation with membrane ≤ 10 x 10 ⁻⁶ m ³ /m ² s Pa									

Note: facade material in these instructions can be replaced with less water absorbing materials e.g. glass, metal, etc.

Timber & metal frame walls (Central European climate; Holzkirchen, Germany)

Initial moisture content of the structure max 80% (RH equilibrium)

Building height and facade material									
		2 floors ≤ 7 m		4–5 floors ≤ 14–18 m		8–9 floors ≤ 28–32 m		16 floors ≤ 56 m	
		Wood or cement fiber board	Brick	Wood or cement fiber board	Brick	Wood or cement fiber board	Brick	Wood or cement fiber board	Brick
Needed air-flow rate in ventilation gap, in ventilation gap, yearly average, dm ³ /s m ²		0,025	0,34	0,025	0,34	0,025	0,34	0,025	0,34
Needed air-flow rate in ventilation gap with different building heights (dm ³ /s m ²) per wall width (e.g. 7 x 0,025 = 0,175 dm ³ /s m)		0,175	2,38	0,450	6,12	0,800	10,88	1,400	19,04
Dimensioning of ventilation openings (mm ² /m) leading air to ventilation gap to reach the needed ventilation rate									
Width of ventilation gap	45 mm	170	2500	380	5500	600	9600	890	-
	25 mm	190	2650	390	7400	620	-	940	-
	45 mm + Fire barrier	280	-	680	-	-	-	-	-
	25 mm + Fire barrier	280	-	10000	-	-	-	-	-
Required air permeability / air-flow resistivity for insulation layer to avoid convection:		≤ 30 x 10 ⁻⁶ m ³ /m s Pa		≤ 40 x 10 ⁻⁶ m ³ /m s Pa		≤ 40 x 10 ⁻⁶ m ³ /m s Pa ≤ 30 x 10 ⁻⁶ m ³ /m s Pa, in case of additional openings (e.g window openings)			
It is always good to use lower air permeability than required. With fire barriers it is recommended to use more air tight wind protection insulation with membrane ≤ 10 x 10 ⁻⁶ m ³ /m ² s Pa									

Note: facade material in these instructions can be replaced with less water absorbing materials e.g. glass, metal, etc.

CLT walls (Central European climate; Holzkirchen, Germany)

Initial moisture content of the structure max 67% (RH equilibrium)

Building height and facade material									
		2 floors ≤ 7 m		4–5 floors ≤ 14–18 m		8–9 floors ≤ 28–32 m		16 floors ≤ 56 m	
		Wood or cement fiber board	Brick	Wood or cement fiber board	Brick	Wood or cement fiber board	Brick	Wood or cement fiber board	Brick
Needed air-flow rate in ventilation gap, in ventilation gap, yearly average, dm ³ /s m ²		0,037	0,34	0,037	0,34	0,037	0,34	0,037	0,34
Needed air-flow rate in ventilation gap with different building heights (dm ³ /s m ²) per wall width (e.g. 7 x 0,037 = 0,259 dm ³ /s m)		0,259	2,38	0,666	6,12	1,184	10,88	2,072	19,04
Dimensioning of ventilation openings (mm ² /m) leading air to ventilation gap to reach the needed ventilation rate									
Width of ventilation gap	45 mm	240	2500	500	5500	770	9600	1140	-
	25 mm	240	2650	500	7400	800	-	1240	-
	45 mm + Fire barrier	280	-	680	-	-	-	-	-
	25 mm + Fire barrier	280	-	10000	-	-	-	-	-
Required air permeability / air-flow resistivity for insulation layer to avoid convection:		≤ 30 x 10 ⁻⁶ m ³ /m s Pa		≤ 40 x 10 ⁻⁶ m ³ /m s Pa		≤ 40 x 10 ⁻⁶ m ³ /m s Pa ≤ 30 x 10 ⁻⁶ m ³ /m s Pa, in case of additional openings (e.g window openings)			
It is always good to use lower air permeability than required. With fire barriers it is recommended to use more air tight wind protection insulation with membrane ≤ 10 x 10 ⁻⁶ m ³ /m ² s Pa									

Note: facade material in these instructions can be replaced with less water absorbing materials e.g. glass, metal, etc.

Concrete, aerated concrete block and brick walls (Central European climate; Holzkirchen, Germany)

Initial moisture content of the structure: Concrete max. 95% Aerated concrete or brick max. 85% (RH equilibrium)

Building height and facade material									
		2 floors ≤ 7 m		4–5 floors ≤ 14–18 m		8–9 floors ≤ 28–32 m		16 floors ≤ 56 m	
		Wood or cement fiber board	Brick	Wood or cement fiber board	Brick	Wood or cement fiber board	Brick	Wood or cement fiber board	Brick
Needed air-flow rate in ventilation gap, in ventilation gap, yearly average, $\text{dm}^3/\text{s m}^2$		0,062	0,34	0,062	0,34	0,062	0,34	0,062	0,34
Needed air-flow rate in ventilation gap with different building heights ($\text{dm}^3/\text{s m}^2$) per wall width (e.g. $7 \times 0,062 = 0,434 \text{ dm}^3/\text{s m}$)		0,434	2,38	1,116	6,12	1,984	10,88	3,472	19,04
Dimensioning of ventilation openings (mm^2/m) leading air to ventilation gap to reach the needed ventilation rate									
Width of ventilation gap	45 mm	340	2500	710	5500	1100	9600	1660	-
	25 mm	350	2650	720	7400	1150	-	1900	-
	45 mm + Fire barrier	280	-	680	-	-	-	-	-
	25 mm + Fire barrier	280	-	10000	-	-	-	-	-
Required air permeability / air-flow resistivity for insulation layer to avoid convection:		$\leq 30 \times 10^{-6} \text{ m}^3/\text{m s Pa}$		$\leq 40 \times 10^{-6} \text{ m}^3/\text{m s Pa}$		$\leq 40 \times 10^{-6} \text{ m}^3/\text{m s Pa}$ $\leq 30 \times 10^{-6} \text{ m}^3/\text{m s Pa}$, in case of additional openings (e.g window openings)			
It is always good to use lower air permeability than required. With fire barriers it is recommended to use more air tight wind protection insulation with membrane $\leq 10 \times 10^{-6} \text{ m}^3/\text{m}^2 \text{ s Pa}$									

Note: facade material in these instructions can be replaced with less water absorbing materials e.g. glass, metal, etc.

Dimensioning of openings

The areas of the air inlet and outlet openings are usually presented in mm^2/m . This corresponds to the area of one opening per the width of the structure. Both the inlet and outlet openings are assumed to have the same area, and the total opening area is, therefore, two times higher than what is presented in the dimensioning tables.

If the ventilation has only one opening that can be adjusted, and the other end is fully open, the presented opening areas can be applied, even if it results in a excessively high ventilation of the wall.

When the air-flow rate exceeds the needed level, the only way to adjust it to the required level is to increase the air-flow resistance of the air in/outlet openings by decreasing the opening area.

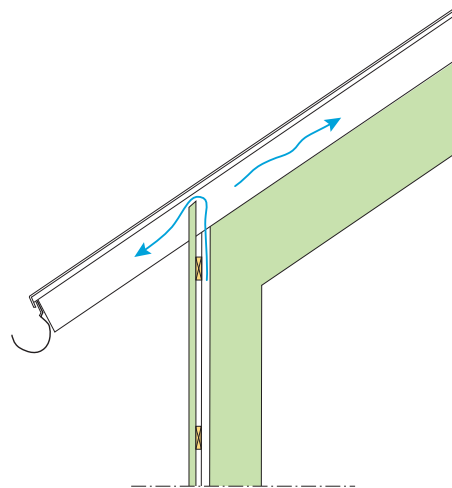

The minimum size of the ventilation dimensioning table applies to the dimensioning of the ventilation openings in both the lower and upper part of the facade. The ventilation outlet at the top of the facade is assumed to always be open, so for this the design values in the table are easily achieved.

Brick facades

In brick facades, ventilation openings are made in the vertical seams of the lower part of the brick cladding according to the table below.

Height of the brick (mm)	Area of the vertical seam (mm ²)	Total area of openings (mm ² /m)				
		Every 3. vertical seam open	Every 3. vertical seam open 2 x **	Every 2. vertical seam open	Every 2. vertical seam open 2 x **	Every vertical seam open
		1 opening/m	2 openings/m	2 openings/m	4 openings/m	3 openings/m
60	1125 (1350*)	1125 (1350*)	2250 (2475*)	2250 (2475*)	4500 (4950*)	3375 (4050*)
75	1350 (1575*)	1350 (1575*)	2700 (2925*)	2700 (2925*)	5400 (5625*)	

* In the first row it is possible to make openings bigger by leaving the mortar out of the top and bottom seam (h= 60 mm + 15 mm + 15 mm or h= 75 mm + 15 mm + 15 mm)

** Ventilation openings are placed in the 1st and 4th brick layers

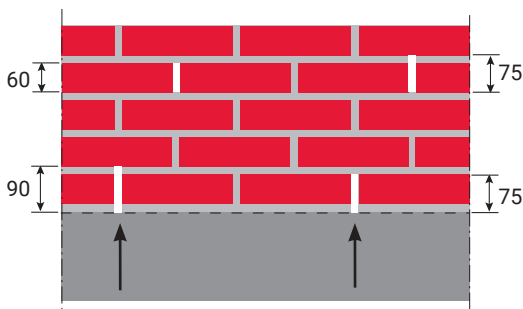

Example: Dimensioning of ventilation opening (mm²/m) for brick facade, when brick height is 60 mm and every second seams is left open.

Openings in the first brick row:

$$15 \times 75 \text{ mm} = 1125 \text{ mm}^2 \text{ (or } 15 \times 90 \text{ mm} = 1350 \text{ mm}^2)$$

$$\rightarrow 2 \text{ openings/m} = 2 \times 1125 \text{ mm}^2/\text{m} = 2250 \text{ mm}^2/\text{m}$$

$$\rightarrow 4 \text{ openings/m (openings in 1. and 4. brick row)} =$$

$$4 \times 1125 \text{ mm}^2/\text{m} = 4500 \text{ mm}^2/\text{m}$$

If there are more openings in the wall ventilation route, the maximum height of the ventilation route from opening to next opening can be considered as the design height. In this case the minimum opening area for each opening is set by this design height. For example, a 28-m high building has ventilation openings at 7 m distance. The design height for the ventilation openings is 7 m and there are five about similar openings in the ventilation route. This approach can be applied to window openings that includes facade ventilation openings. The total opening area should be fulfilled, and each opening should be at least 50 % of the total area divided equally for each opening.

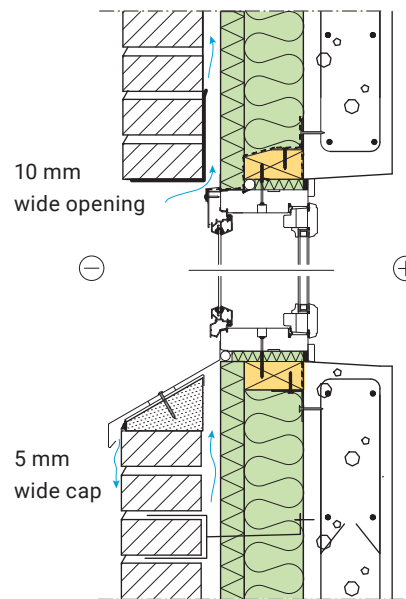

Width of the window or door (mm)	Ventilation opening area above the window /door (mm ²)	Ventilation opening area below the window /door (mm ²)
1000	10000	2500–5000
1200	12000	3000–6000
1500	15000	1125 (1350*)
1800	18000	1350 (1575*)
2100	21000	5350–10500

Opening area size above the window/door = width x 10 mm

Opening area size below the window/door = width x 5 mm.

Fixing materials might reduce the size of the ventilation gap below the window/door ~ 0 – 50%

Fire barriers

Note: Opening areas presented in here mean the actual free open areas of the openings, considering, for example, the protection nets against animals or other similar structures reducing the actual open area.

Fire barriers can be used in ventilation gaps for two reasons: together with a combustible facade or for insulation.

If the facade material is having fire class D or weaker (for example, wooden cladding) the ventilation gaps might require fire protection with horizontally installed fire barriers on each floor. This need should be checked from the local fire regulations. The most common solution is to use a perforated metal profile; but from the ventilation point of view, it would be better to use expanding options to keep the air channels open.

Possible fire barriers are reducing the air-flow in the ventilation gap.

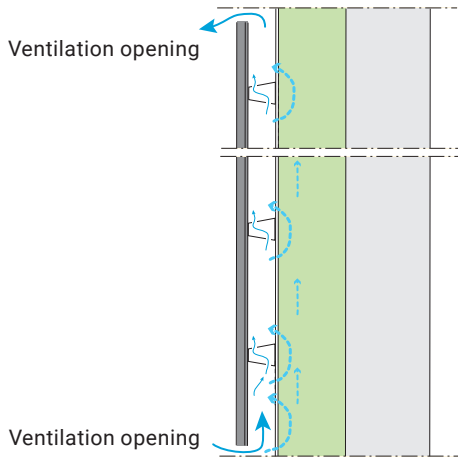

Ventilation cavities with fire barriers are typically applied with timber facades, as stone wool insulation is non-combustible. The fire barriers might cause significant air-flow resistances, reducing the maximum practical height of the ventilation cavity, and they also tend to cause strong convection flow into thermal insulation. A separate wind protection membrane is recommended in all structures having fire barriers in the ventilation cavity. The recommended maximum air permeance of the wind barrier layer is $10 \times 10^{-6} \text{ m}^3/\text{m}^2 \text{ s Pa}$.

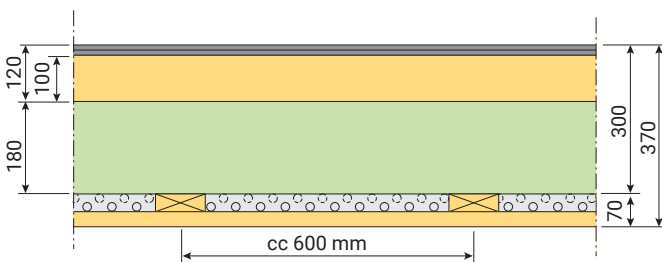

e.g. One fire barrier on each floor (cc in vertical direction ~3,3 m) and each break has two sides with 5 % open area compared to the cross section of the ventilation cavity.

For example in following construction with a 45 mm-wide ventilation gap, the size of opening area is: $[(1000 \text{ mm} \times 45 \text{ mm}) - (1,66 \times 45 \text{ mm} \times 100 \text{ mm})] = 37\,530 \text{ mm}^2/\text{m} \rightarrow$ Due to the fire barrier, the opening size reduction is 95% $\rightarrow 0.05 \times 37\,530 \rightarrow$ Size of ventilation opening is, therefore, $1876 \text{ mm}^2/\text{m}$.

Horizontal fire spread can be prevented in the wall area of escape routes and staircases with vertically installed fire barriers.

The width of the ventilation gap

The effect of the ventilation gap width (45 mm/25 mm) is quite low in cases with an open ventilation cavity; but when there are fire breaks in the cavity, the effect is significant, as fire breaks can decrease the cross-section area of the ventilation cavity by up to 95%. In the case with a 45-mm gap width, the fire breaks have an 80 % higher open area than in the 25 mm case, which has a considerable effect on the air-flow resistance of the breaks.

To achieve an adequate wall ventilation air-flow rate in structures with fire breaks, there should be additional ventilation openings in the walls of high buildings. The maximum distance between ventilation openings is generally ~18 m.

If there are more frequent fire breaks (or similar air-flow obstructions in the ventilation channel) than assumed here (one per each floor at 3,3 m distance), it will be even more difficult to achieve the desired wall ventilation air-flow rate.

2.2 DESIGN OF THERMAL INSULATION

THERMAL INSULATION LAYER

Insulation used in a ventilated facade must have certain air-flow resistivity to avoid convective heat losses through the wall. There are at least three different occasions in wall ventilation that have different effects on convective air-flow in the thermal insulation layer.

- 1. The pressure gradient in the ventilation cavity in the direction of the cavity.** Air-flows in the cavity parallel to the surface of the thermal insulation. When the cavity is relatively open most of the air-flows in the cavity, not through the insulation layer, having a significantly higher air-flow resistance than the cavity. Temperature differences between the thermal insulation and ventilation air can increase natural convection inside the insulation layer if the insulation is very porous (air permeable). This may increase the convection and affect the heat losses more than the wind-caused pressure difference over the cavity length.
- 2. Air-flow through the ventilation openings.** Wind causes dynamic pressure fields in the openings, and depending on the opening area, the air-flow velocity levels through the opening can be high. When this air-flow hits the thermal insulation surface, in some cases perpendicularly, it can cause high pressure differences and strong local convection in the thermal insulation.
- 3. Pressure differences over the structural details in the ventilation cavity.** When the ventilation cavity has some structural details that cause strong resistance for the flow, the air-flow tends to bypass this obstruction by flowing through the thermal insulation layer.

Natural convection

From the natural convection perspective, the maximum air permeability for the insulation products used in ventilated facades should be around $50 \times 10^{-6} \text{ m}^3/\text{m s Pa}$. Natural convection can occur in insulation layers purely due to big temperature differences between the inside and outside. If the insulation is too "light", meaning that there is no resistance for air-flow, the heat might start to move inside the insulation layer, weakening the energy efficiency of the construction especially on cold winter days when the temperature difference is high:

- If the insulation's air permeability is between 70 to $190 \times 10^{-6} \text{ m}^3/\text{m s Pa}$, the heat transfer coefficient of the walls might increase by 10–14% due to natural convection. This increase may be compensated by increasing the thickness of a thermal insulation layer or using separate wind protective products or membranes.
- Insulation layers with air permeability of more than $190 \times 10^{-6} \text{ m}^3/\text{m s Pa}$ shall always be protected with wind protective products or membranes.

Forced convection

Wind-caused pressure differences close to the ventilation openings can cause high convection flow into the thermal insulation, especially close to the opening on the bottom of the ventilation cavity, where natural convection enhances the colder outdoor air-flow into the structure. This can result in significant changes in local temperature conditions, which affect the heat losses and even the thermal comfort locally.

Our recommendation is to install a wind barrier layer on the top of the thermal insulation installed on each floor where there are ventilation openings that allow air-flow to hit the thermal insulation layer, causing considerable additional convection flow in the insulation layer. The aim is to shelter the thermal insulation from these local high dynamic pressure gradients and to guide the air-flow in the direction of the ventilation cavity. The recommended maximum air permeance of the wind barrier layer is $10 \times 10^{-6} \text{ m}^3/\text{m}^2 \text{ s Pa}$.

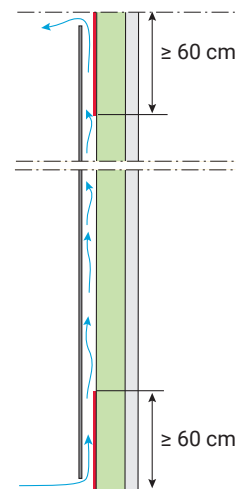

The easiest solution is to use wind protective insulation, e.g., PAROC Cortex, in areas where the ventilation openings are located. It is also possible to use separate 60 cm-wide Tyvek-membrane layer PAROC Cortex-membrane (XMW 068), on the top of the wall insulation slabs. The recommendation is valid for all facade materials.

The air permeability of the insulation between the openings can be set according to the results presented in the ventilation dimensioning tables.

U-value calculation

The U-value calculation for a ventilated facade structure is made in accordance with ISO EN 6946. The total thermal resistance of an external wall containing a well-ventilated air layer shall be obtained by disregarding the thermal resistance of the air layer and all other layers between the air layer and external environment, and including an external surface resistance corresponding to still air. Alternatively, the corresponding value of $R_{si} = 0.13$ may be used for both internal and external surfaces.

$$R_T = R_{si} + R_1 + R_2 + R_3 \dots + R_n + R_{se}$$

where

$$R_i = d_i / \lambda_i$$

R_T = the total thermal resistance, (m^2K/W)

R_{si}/R_{se} = is the internal/external surface resistance (m^2K/W)

R_i = thermal resistance of one material layer (m^2K/W)

d_i = thickness of one material layer (m)

λ_i = thermal conductivity of one material layer (W/mK)

Surface resistances

	Direction of heat flow		
	Upwards	Horizontal	Downwards
R_{si} (interior)	0,10	0,13	0,17
R_{se} (exterior)	0,04	0,04	0,04

The U value is first calculated for the structure without the cold bridges in the insulation layer, $U = 1 / R_T$

Correction for Mechanical fasteners (cold bridges)

A thermal bridge, also called a cold bridge, is an area of a building construction which has a significantly higher heat transfer than the surrounding materials. In ventilated facades, cold bridges are formed by metal brackets and fasteners penetrating the insulation layer. These paths allow heat flow to bypass the insulating layer and reduce the effectiveness of the insulation and the overall building thermal envelope.

The amount and size of brackets depends on the insulation thickness, as well as the different loads the facade system shall carry (like weight of facade material and wind). As metal brackets have significantly higher thermal conductivity than insulation, their dimensions and material play a significant role especially in buildings situated in a cold climate.

Point thermal bridges, such as brackets, brick

ties, and insulation fasteners that are distributed uniformly throughout the surface area of a wall, shall be considered when calculating the U- value for the structure. The effect of mechanical fasteners (e.g., wall brackets) on the insulation layer is considered in the U- value calculation of the structure, by using the ΔU_f correction. If the total correction exceeds 3% of the calculated thermal transmittance, the correction shall be applied, and the ΔU_f correction added to the calculated U- value.

Metal frame systems with brackets

All metal frame manufacturers have their own specific thermal transmittance values (χ) for their brackets. The Chi-factor (χ) is determined in accordance with the ISO 10211 modeling procedures. Also, the number of fasteners is designed by system manufacturers, based on the building's facade material, details, and loads. If these values are known, the ΔU_f correction can be calculated easily, just multiplying the thermal transmittance value with the number of fasteners:

$$\Delta U_f = n_f \cdot \chi$$

n_f = number of fasteners per m^2 ($1/m^2$)

χ = the Chi-factor or point transmittance of the fastener as used in the particular assembly

If the bracket's thermal transmittance value is not known, the approximate effect of mechanical fasteners can be calculated using following formula:

$$\Delta U_f = \alpha \cdot \frac{\lambda_f \cdot A_f \cdot n_f}{d_i} \cdot \left(\frac{R_i}{R_{tot}} \right)^2$$

ΔU_f = the correction for mechanical fasteners (W/m^2K)

A_f = the cross-sectional area of one fastener (m^2)

λ_f = the thermal conductivity of the fastener (W/mK)

n_f = the number of fasteners per m^2 ($1/m^2$)

R_i = thermal resistance of the insulation layer penetrated by fasteners (m^2K/W)

R_{to} = the total thermal resistance of the structure ignoring any thermal bridging (m^2K/W)

$\alpha = 0,8$, if the fastener fully penetrates the insulation layer

In case of a recessed fastener

$$\alpha = 0,8 \cdot d_1 / d_0$$

d_0 = the thickness of the insulation layer containing the fastener (m)

d_1 = the length of the fastener that penetrates the insulation layer (m)

The bracket size and number of fasteners per m^2

(1/m²) depends on the facade loads; therefore, it is the designer's responsibility to do the needed dimensioning. Vertical fixing profiles for facade material are usually installed cc 600mm, but dimensioning is based on the facade cladding needs. For the thick insulation layers or heavier facade materials, brackets are usually bigger than with thin insulation layers or light facade materials. The average amount of fasteners is ~3–4 fasteners/m².

Different metal qualities used in brackets have very different lambda values. The table below shows the thermal conductivities of the most typical metals used in fasteners. The higher the thermal conductivity of the metal, the greater the cold bridge effect of the fastener.

Metal	Thermal conductivity (λ), W/mK
Aluminum	220
Steel	50
Stainless steel	17

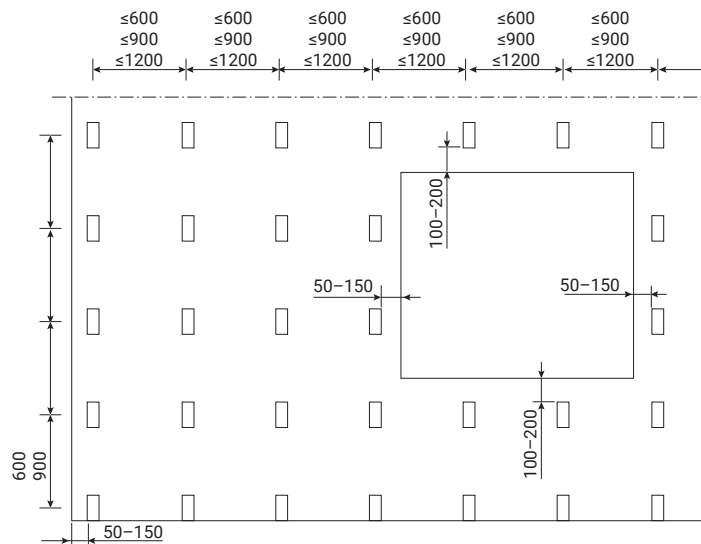

Calculation example:

The ventilated facade system is installed on a 150 mm concrete wall, with L-shaped wall brackets made of stainless steel. The height of the bracket passing through the insulation layer is 150 mm, and the material thickness of a bracket is 3 mm, 4 brackets/m². How thick of an insulation layer of PAROC Cortex One is needed to achieve a U-value of 0.17 W/m²K?

Bracket, stainless steel, lambda (W/mK)	17
Height of bracket (mm)	150
Thickness of metal used in bracket (mm)	3
Cross sectional area of bracket (m ²)	0,00045
Number of fasteners per m ²	4
R _{si} + R _{se} (m ² K/W)	0,13 + 0,13 = 0,26
Thickness of concrete core (m)	0,150
Concrete, thermal conductivity (W/mK)	2,5
R ₂ concrete core	0,06
R ₁ Insulation (m ² K/W)	d ₁ /0,033
U _c value demand (W/m ² K) for construction	0,17 → U = 1/R → R = 1/U → target R = 5,88 m ² K/W

From these values we can calculate needed insulation thickness without cold bridges:

$$R_{tot} = R_{si} + R_2 + R_1 + R_{se}$$

$$R_{tot} = 0,13 + 0,06 + d/0,033 + 0,013 = 5,88$$

→ without brackets required insulation thickness would be ~183 mm

$$R_1(\text{insulation}) 0,183/0,033 = 5,54 \text{ m}^2\text{K/W}$$

In the table next page, you will find both the approximate correction factors (ΔU_f) for the wall brackets and the level of insulation thickness required to compensate for the effect of the cold bridge. If cold bridges wouldn't be taken into account, the desired U-value could be achieved with an insulation thickness of 180 mm. But in ventilated facade systems, the number of wall brackets is large, so the effect of cold bridges is also large. Thus, when the cold bridging correction (ΔU_f) of stainless-steel fasteners is added to the above value, the U-value becomes too large, being 0.29 W/m²K. With other fastening materials, the effect on the U-value is even greater.

When you go down to the column "Corrected U-values for stainless steel", you will see that the **U-value of 0.17 W/m²K can be achieved in this case with a 320 mm thick insulation layer.**

The best way to reduce the effect of a cold bridge and the insulation thickness would be to use fewer brackets with lower lambda and a smaller cross-sectional area passing through the insulation layer. This is not always possible because the dimensions of the fasteners are based on the dimensions of the entire facade system.

$$\Delta U_f = \alpha \cdot \lambda_f \cdot A_f \cdot n_f \cdot R_1$$

$$\frac{1}{d_1} \left(\frac{1}{R_{tot}} \right)^2$$

Correction factor (ΔU_f) examples for 3 mm thick and 150 mm high L-shape brackets, 4 pcs/m², $\alpha = 0,8$

Insulation thickness	R ₁ (insulation)	R ₂ (concrete)	R _{tot}	ΔU_f	ΔU_f	ΔU_f	U value without correction	Corrected U-value, Stainless steel	Corrected U-value, Steel	Corrected U-value, Aluminum
d ₁	R ₁ (Cortex One, $\lambda=0,033\text{W/mK}$) [m ² K/W]	150 mm concrete, ($\lambda=2,5\text{W/mK}$) [m ² K/W]	R _{tot} = R _{si} + R ₁ + R ₂ + R _{se} [m ² K/W]	Aluminum ($\lambda=220\text{W/mK}$) [m ² K/W]	Steel ($\lambda=50\text{W/mK}$) [m ² K/W]	Stainless steel ($\lambda=17\text{W/mK}$) [m ² K/W]	[m ² K/W]	[m ² K/W]	[m ² K/W]	[m ² K/W]
0,150	4,545	0,06	4,865	1,843	0,419	0,142	0,206	0,348	0,625	2,049
0,160	4,848	0,06	5,168	1,742	0,396	0,134	0,193	0,328	0,589	1,935
0,170	5,152	0,06	5,472	1,651	0,375	0,127	0,183	0,310	0,558	1,834
0,180	5,455	0,06	5,775	1,570	0,356	0,121	0,173	0,294	0,529	1,743
0,190	5,758	0,06	6,078	1,496	0,340	0,115	0,165	0,281	0,505	1,661
0,200	6,061	0,06	6,381	1,428	0,324	0,110	0,157	0,267	0,481	1,585
0,210	6,364	0,06	6,684	1,367	0,310	0,105	0,150	0,255	0,460	1,517
0,220	6,667	0,06	6,987	1,310	0,298	0,101	0,143	0,244	0,441	1,453
0,230	6,970	0,06	7,290	1,259	0,286	0,097	0,137	0,234	0,423	1,396
0,240	7,273	0,06	7,593	1,210	0,275	0,093	0,132	0,225	0,407	1,342
0,250	7,576	0,06	7,896	1,166	0,265	0,090	0,127	0,217	0,392	1,293
0,260	7,879	0,06	8,199	1,125	0,255	0,087	0,122	0,209	0,377	1,247
0,270	8,182	0,06	8,502	1,086	0,246	0,083	0,118	0,201	0,364	1,204
0,280	8,485	0,06	8,805	1,050	0,238	0,081	0,114	0,195	0,352	1,164
0,290	8,788	0,06	9,108	1,016	0,231	0,078	0,110	0,188	0,341	1,126
0,300	9,091	0,06	9,411	0,985	0,224	0,076	0,106	0,182	0,330	1,091
0,310	9,394	0,06	9,714	0,955	0,217	0,073	0,103	0,176	0,320	1,058
0,320	9,697	0,06	10,017	0,927	0,210	0,071	0,100	0,171	0,310	1,027

$$R_{si} + R_{se} = 0.26 \text{ W/m}^2\text{K}$$

Brick walls with brick ties

Cold bridge effect is also present in brick walls as brick facade must be supported to sub-structure by using metal ties through the insulation layer. The size of a tie is usually \varnothing 4 mm and number of ties is $\sim 4 - 6 / \text{wall-m}^2$.

The cold bridge effect of brick ties is calculated by using same formula than used for metal brackets.

Calculation example:

$$R_{si} = 0,13 \text{ m}^2\text{K/W}$$

$$\text{Brick wall } 130 \text{ mm } (\lambda_{uj} = 1,0 \text{ W/mK}), R = 0,13 \text{ m}^2\text{K/W}$$

$$\text{Thermal insulation } 175 \text{ mm } (\lambda_{uj} = 0,036 \text{ W/mK}), R = 4,86 \text{ m}^2\text{K/W}$$

$$\lambda_{uj} \text{ for stainless steel ties} = 17 \text{ W/mK}$$

$$\text{Wind protection insulation } 30 \text{ mm } (\lambda_{uj} = 0,033 \text{ W/mK}), R = 0,90 \text{ m}^2\text{K/W}$$

$$R_{se} = 0,13 \text{ m}^2\text{K/W}$$

$$R_T = (0,13 + 0,13 + 4,86 + 0,90 + 0,13) \text{ m}^2\text{K/W} = 6,15 \text{ m}^2\text{K/W} \text{ (without cold bridges)}$$

$$U = 1/R_T = 1/6,15 \text{ m}^2\text{K/W} = 0,162 \text{ W/m}^2\text{K}$$

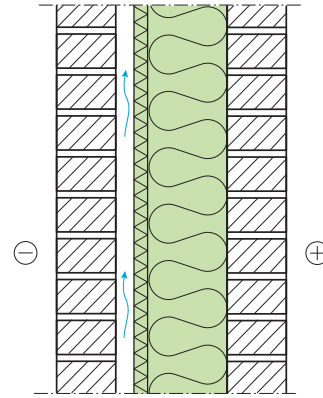

Cold bridges are calculated from the formula:

$$\Delta U_f = \alpha \cdot \frac{\lambda_f \cdot A_f \cdot n_f}{d_1} \cdot \left(\frac{R_1}{R_{tot}} \right)^2$$

Tie, stainless steel, lambda (W/mK) 17

Height of tie (mm) 30 + 175

Thickness of metal used in tie (mm) \varnothing 4

Cross sectional area of tie (m^2) $A_f = \pi (4 \text{ mm})^2 / 4 = 12,6 \text{ mm}^2 = 0,0000126 \text{ m}^2$

Number of fasteners per m^2 6/ m^2

$R_1 = d_0 / \lambda_{insulation} = 0,03/0,033 + 0,175/0,036 = 5,77 \text{ m}^2\text{K/W}$

$R_T = 6,15 \text{ m}^2\text{K/W}$

$$U_f = 0,8 \cdot [(17 \cdot 0,0000126 \cdot 6)/0,205] \cdot (5,77/6,15)^2 = 0,0047 \text{ W/m}^2\text{K}$$

0,0047/0,162 = 2,9% (< 3%). When correction effect is less than 3%, there is no need to do the correction to U value.

Final U value is therefore 0,16 W/m²K

3. PAROC PRODUCTS

PAROC insulation products are not just good thermal insulators – in the same product, you also receive excellent fire properties and moisture performance for your constructions.

FIRE PROPERTIES

All PAROC Stonewool products belong to the best fire class, A1, and wind protective insulation with Cortex-covering to fire class A2-s1, d0. This means that these products don't contribute to the spread of fire, and you can use them in all different types of buildings. Non-combustible stone wool keeps its form in fire, so it protects all the other materials and property from fire spread. This gives more time for people to leave the building and fire fighters to work

MOISTURE PROPERTIES

Due to the porous material structure, mineral wool helps surrounding wall structures to dry faster than other insulation materials. Stone wool won't block the moisture into the structure – it allows moisture to dry fast. Due to open fiber structure, moisture can't condense on the inside of the stone wool insulation layer.

Stone wool is inorganic material; 96–98 % of its weight is from volcanic stone. The remaining 2–4 % is an organic binder. PAROC Stonewool products have been tested in an external laboratory* and found resistant towards mold growth. The test was conducted at 95–100% relative

humidity and 22°C temperature for 28 days with most typical mold species found in buildings. (* SP Sweden, test report ETi PXX07404/17.2.2011)

According to external studies, calculations and simulations carried out for ventilated facades with wooden paneling, facade boards, and brick facade, no moisture or mold risks were detected in any parts of the structure. PAROC Stonewool insulated structures were studied in assumed 2030 climate conditions, setting the relative humidity parameter to RH 80% and RH 95% by using the Mold Index -model developed by VTT (Viitanen 2001). (*Sweco RA08_61351/16.12.2015)

The stone wool is water repellent (hydrophobic), which means that it repels moisture in liquid form. It won't absorb water either from the surrounding air, even in extremely high relative humidity (RH98%). Only dry insulation works as planned.

Soft stone wool insulation is easy to install. In insulation work, the insulation boards are installed tightly together or against the structure with butt joints, in which case the space seams are automatically sealed with wool fibers, and no separate sealing products are needed. Stone wool insulation is stable over the long term: it maintains its dimensions and insulation properties in different climate conditions and temperatures.

PAROC HAS A WIDE PRODUCT SELECTION FOR VENTILATED FACADES

PAROC Cortex One – for 1-layer insulation solution

- PAROC Cortex One is a perfect solution for ventilated facades. One thick insulation layer with an integrated wind protection membrane makes facade insulation work easy and fast. Excellent air tightness (air permeability coefficient of the membrane is $< 10 \times 10^{-6} \text{m}^3/\text{m}^2 \text{s Pa}$) and water tightness are achieved by using the vapor-open Tyvek FireCurb -membrane on top of a stone wool slab. Good vapor permeability allows possible moisture to dry safely without causing condensation problems inside the construction. Thick stone wool insulation has very low lambda glass 0.033W/mK, which helps to reduce insulation thickness compared to two-layer insulation solutions.
- PAROC Cortex One has a fire classification of A2, s1-d0, which allows the product to be used in all types of buildings. PAROC Cortex One can also be used as a protective covering (K₂30) for wooden constructions.
- The airtightness of the wind protection layer is ensured by taping all the seams with PAROC Cortex tape (XST 022) and corners with PAROC Cortex corner tape (XST 021).

PAROC Cortex (pro) – for 2-layer insulation solution

- PAROC Cortex and Cortex pro-wind protection insulation slabs can be used as an external layer in a two-layer system in combination with another thermal insulation layer, like PAROC eXtra. With a two-layer system you can create a continuous thermal insulation layer with staggered joints to improve the thermal performance of the wall.
- All white Cortex slabs are covered with Tyvek FireCurb -membrane. The PAROC Cortex and Cortex pro products are also available with a black glass fiber tissue based membrane. Seams are taped, as with PAROC Cortex One. With a black covering, the tapes are also black; for seams PAROC Cortex black tape (XST 042) and corners PAROC Cortex black, corner tape (XST 041).
- PAROC Cortex boards are very energy efficient. The lambda of PAROC Cortex is 0.033 and PAROC Cortex pro 0.032 W/mK.



PAROC Cortex tape (XST 022) and PAROC Cortex corner tape (XST 021) (white)

PAROC Cortex black tape (XST 042) and PAROC Cortex black, corner tape (XST 041) (black)



- PAROC Cortex- tapes are highly adhesive sealing tapes used to seal the joints of Cortex wind protection insulation.
- Seam tapes are available in widths of 60 and 100 mm. The tape is used for approximately 1.5 m/m². For Cortex One, a consumption is a bit bigger, approximately 2.5 m/m².
- The widths of the corner strips are 350 mm (white) and 310 mm (black).
- The seams and connections of the wind protection insulation slabs must be taped when installing the insulation. The amount of adhesive used to bond wind protective membrane to stone wool is minimized for best fire safety, so wind entering under the coating can tear the non-taped coating off its substrate. The taping surfaces must be clean and dry.
- Sealing tape has a storage temperature of +5 to +25 °C. Indoor storage. Installation temperature -10 to +40 °C.

PAROC Tendo (t,tb,tt) – for 1- or 2-layer insulation solution



- The high airflow resistance of PAROC Tendo products is achieved with a dense fibrous structure of the insulation that is the same throughout the thickness of the insulation slab. The surface of PAROC Tendo products can be covered with a thin natural (t) or black (tb) fiberglass veil. PAROC Tendo tt has a thin natural glass fiber coating on both sides of the product, which makes handling a large slab easier.
- PAROC Tendo's air permeability coefficient (t, tb, tt) is <math> < 30 \times 10^{-6} \text{ m}^2/\text{Pa}\cdot\text{s}</math>, so it is well suited for ventilated facades of buildings of all heights.
- PAROC Tendo (t,tb,tt) have excellent lambda value, 0.033 W/mK, and it belongs to highest fire class, A1.
- In the area of the ventilation openings, where the wall insulation is subjected to a perpendicular flow of air, we recommend using a tighter PAROC Cortex-membrane (XMW 068) on top of the PAROC Tendo insulation board. Another option is to do this part of the wall by using PAROC Cortex slabs.

PAROC eXtra/eXtra pro - thermal insulation for 2-layer insulation solution



- PAROC eXtra / Ultra products are soft universal insulations which can be used in combination with thinner PAROC Cortex and PAROC Tendo wind protection insulations as a thermal insulation layer.
- The lambda of PAROC eXtra is 0.036 W/mK. If installation space is limited, it is better to choose a more energy-efficient PAROC eXtra pro with a lambda of 0.033 W/mK.
- Uncoated PAROC eXtra products belong to the best A1 fire class.

PAROC Distancer (XFP 001) is tubular shaped and made of polyethylene, HD quality.

PAROC Distancer Cortex (XFP 002) with pins are made of polyethylene, HD quality.

PAROC Washer plastic (XFW 004)



- The PAROC Distancer (XFP 001) is used together with nails/screws in insulation installation.
- With the Cortex products, it is easier to use PAROC Distancer Cortex (XFP 002) as the membrane has a higher puncture resistance.
- Distancers are available for insulation thicknesses 30 – 95 mm.
- The PAROC Washer plastic (XFW 004) is used together with nails/screws in insulation installation.



Insulation dowel SFS RP50/BS-4,8 wood (XFM 006)

(Insulation holder for wood)

Insulation dowel SFS RP50/TI-T25-6,3 concrete (XFM 007)

(Insulation holder for concrete)

- The Insulation dowel SFS RP50/BS-4,8 wood (XFM 006) is an insulation holder for wooden substrates. The fastener is made of polypropylene. Wood screw Torx T25 and PAROC XFT 005 Bits are included in the packaging.
- The Insulation dowel SFS RP50/TI-T25-6,3 concrete (XFM 007) is an insulation holder for concrete substrates. The fastener is made of polypropylene. Concrete screw Torx T25 and PAROC Screwdriver Bit T25 (XFT 005) are included in the package. The installation requires predrilling of concrete with PAROC Drill Bit concrete S 5,0 (XFD 002) concrete drill.
- PAROC Drill Bit concrete S 5,0 (XFD 002) with cutter / stop is intended for use in drilling of concrete. The drill is used for pre-drilling before mounting the Insulation dowel SFS RP50/TI-T25-6,3 concrete (XFM 007). For thicker insulation layers, it is recommended to extend the drill bit with the PAROC Drill Bit extension (XFD 003). This is sold separately.
- PAROC Drill Bit extension (XFD 003) is 500 mm long and it has SDS and conical bracket for PAROC Drill Bit concrete S 5,0 (XFD 002). Wedge included to loosen concrete drill from the extension.

PAROC ZEROfix -MOUNTING SYSTEM

Facade screw HECO Topix Plus Therm wood (XFS 006)

(PAROC ZEROfix facade screw for wood)

Facade screw HECO Multi Monti concrete (XFS 004)

(PAROC ZEROfix facade screw for concrete)



- The function of the PAROC ZEROfix facade screw is to transfer the vertical load caused by the weight of the facade as well as the wind load to the load-bearing structure. With the help of screws, a PAROC ZEROfix nailing batten (XRB 001) can be installed outside the insulation layer, to which the facade cladding itself is attached. The nailing batten forms a 36 mm-wide ventilation gap between the insulation and the facade cladding.
- PAROC ZEROfix screws are a self-drilling, double-threaded screws made of special carbon steel. Torx T40 with recessed head.
- Facade screw HECO Topix Plus Therm wood (XFS 006) (ø 8 mm) lengths are available in the range of 200-550 mm.
- Facade screw HECO Multi Monti concrete (XFS 004) (ø 7,5 mm) lengths is available in the range of 200- 400 mm. The installation requires predrilling of concrete with the PAROC Drill Bit concrete L 6,3 (XFD 001).
- PAROC ZEROfix angle tool (XTI 001) is intended for use when mounting the Facade screw HECO Topix Plus Therm at the desired angle. The tool is used to either give an angle of 30 ° or 45 ° to the screw. The screw is placed in the groove and then screwed into the construction at the desired angle.
- PAROC Drill Bit concrete L 6,3 (XFD 001) is a concrete drill with SDS+ fastener. The drill's diameter is 6,3 mm, and it is available in the range lengths of 300-450 mm.
- PAROC ZEROfix facade screw functions as both a distancer and a fastener and is used to install PAROC Cortex One or PAROC Tendo insulations on a ventilated facade.
- PAROC ZEROfix nailing batten (XRB 001) (fire-treated nailing batten)
- The PAROC ZEROfix nailing batten (XRB 001) is a nailing batten for facade cladding, made of spruce (strength class C24) and treated with waterproof fire impregnation. Fire class of wooden batten is B-s1, d0. Size of the nailing batten is 36 x 98 x 3600 mm

4. PAROC INSULATION SOLUTIONS

4.1. TIMBER FRAME CONSTRUCTIONS/CONSTRUCTION EXAMPLE

A wooden frame wall can be built in several different ways. For this reason, for example, fire and sound insulation values for wood structures are usually calculated, e.g., according to Eurocode 5.

When designing a wooden frame wall structure, several different aspects must be taken into account, which have an effect on the fire, thermal, and moisture technical performance of the wall:

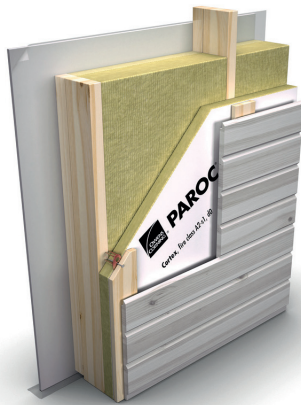

- 13 mm - plaster board
- 50 mm - studding 50 x 50 mm, cc 600 / PAROC eXtra
- Air/vapor barrier PAROC Vapour barrier 020 (XMV 020), taped seams with PAROC Vapour barrier sealing tape (XST 013)
- 125 mm - Timber frame 50 x 125 mm C24, cc 600 / Thermal insulation 125 mm PAROC eXtra or PAROC eXtra pro
- 40 mm Wind protection insulation: PAROC Cortex pro (or PAROC Cortex), taped seams: seams with PAROC Cortex tape (XST 022) and corners with PAROC Cortex corner tape (XST 021)
- 22 mm ventilation gap - PAROC Distancer Cortex (XFP 002) + vertical nailing batten 22 x 100 mm, cc 600
- Wooden cladding

REI 60, load 5,5 kN per stud/9,2kN/m (EUF129-19003518-T1)

R_w 42 dB/R_w + C 40 dB/R_w + Ctr 37 dB

INTERNAL WALL STRUCTURE

Building boards installed on the inner surface of a structure often protect the building frame from fire and improve the sound insulation of the structure. Dimensioning of fire protection can be done according to Eurocode 5.

A tight-air/vapor-barrier layer is critical for the moisture performance of a wooden structure, as it prevents moist indoor air from penetrating deeper into the structure. A challenge in the design is to ensure the continuity of the vapor-barrier layer, especially at the junctions of structures and vapor-barrier penetrations. All penetrations must be carefully sealed. All wires and cables are always installed to the internal side of the vapor barrier. The internal studding acts in the structure as a vapor-barrier protection and as a wiring installation space. The thermal insulation installed between the studs increases the fire resistance time of the structure as well as the sound insulation.

FRAME STRUCTURE

The timber frame structure is dimensioned according to loads and energy efficiency needs. PAROC stone wool is easy to install between the frame studs, as the firm stone wool stays between the studs without any fasteners. In a fire, stone wool protects the frame from charring. Indeed, stone wool is the only insulation that can be used in the fire dimensioning of wooden structures as a factor that improves fire resistance.

According to fire tests and calculations, the most commonly used wood-framed wall structures insulated with PAROC stone wool reach fire resistance class EI 60 (partitions or non-load-bearing external walls) or REI 60 (load-bearing external walls). (Eurofins statement EUFI29-19003518-T1).

EXTERNAL WALL STRUCTURE

The wind-protection insulation installed on the outer surface of the wooden frame protects both the wooden frame and the thermal insulation layer from changing weather conditions. When the frame is insulated from the outside with a uniform layer of wind protection insulation, the wooden cold bridge passing through the insulation layer breaks and the temperature of the frame structure rises significantly, improving the moisture safety of the structure. The recommended thickness of the wind protection insulation layer is (30–70 mm).

The porous insulation board and the breathable coating in it do not prevent the building moisture from drying out. The wind tightness of the building envelope is ensured by taping the seams and cutting surfaces to the associated structures. If necessary, a stiffening building board layer can be used between the wind protection insulation and the frame.

PAROC Distancer Cortex (XFP 002) is used with wood and board cladding to speed up the installation of nailing battens used in facade cladding fixing.

The spacer prevents the wind-protection insulation from being compressed when installing the nailing batten. The nailing spacer is selected according to the thickness of the wind-protection insulation. The spacer is pushed through the wind-protection insulation against the wooden frame stud and fastened with a screw or nail with a cc 600 (4–6 pcs/m²). Nailing battens are mounted on top of the nailing spacers by nailing or screwing them to the frame structure. Spacers and battens provide the necessary ventilation gap between the wind-protection insulation and the cladding. A uniform sealed layer of wind-protection insulation outside the wooden frame improves not only the moisture safety of the structure but also the energy efficiency of the entire wall structure. Nail spacers are suitable for both new construction and additional insulation of an old wall.

PAROC wind protection insulation products can be used as a protective covering for a wooden frame against external fire. These products provide fire protection of the frame from charring for 10–30 minutes. Fixing of protective covering shall be done according to separate instructions.

Fire classified protective coverings

PAROC Cortex pro	50 - 70 mm	K ₂ 30
------------------	------------	-------------------

There must always be a ventilation gap in the wooden frame wall behind the facade cladding. The use of wood cladding on the facade may require the installation of fire barriers in the ventilation gap. This is a good thing to keep in mind when sizing the ventilation opening and choosing wind protection insulation. We recommend the use of PAROC Cortex products in constructions with fire barriers as obstacles in the ventilation gap increase local convection around them. The tight coating of the Cortex product effectively prevents airflow from entering the insulation.

U values for different insulation thicknesses

	Insulation thickness (mm)							
PAROC eXtra (vertical studding)		50	50			50	50	50
PAROC eXtra (timber frame) or	100	150	125	175		175	175	200
PAROC eXtra pro (timber frame)					150			
PAROC Cortex pro or	40		40	40	50	40	55	55
PAROC Cortex		30						
U-value, W/m ² K	0,25	0,17	0,17	0,17	0,17	0,14	0,13	0,12

Calculation parameters (According to EN 6946):

Vapor barrier $\lambda_U = 0.33$ W/mK, $d = 0.25$ mm $R = 0.001$ m²K/W
 Gypsum board $\lambda_U = 0.25$ W/mK, $d = 9/13$ mm, $R = 0.036/0.052$ m²K/W
 PAROC eXtra $\lambda_U = 0.036$ W/mK
 PAROC eXtra pro $\lambda_U = 0.033$ W/mK
 PAROC Cortex $\lambda_U = 0.033$ W/mK
 PAROC Cortex pro $\lambda_U = 0.032$ W/mK
 Timber frame $\lambda_U = 0.12$ W/mK

Timber frame/studding 50 x 50 - 200 mm, cc 600 mm

Surface resistances: $R_{si} + R_{se} = 0.26$ m²K/W

Corrections to thermal transmittance used in calculation:

- Wooden frame: 50 x 50/150/175/200 mm, cc 600 mm
- ΔU_f = Correction for mechanical fasteners < 3% = 0, no correction needed
- ΔU_g = Correction for air voids = $\Delta U''$: Level 0 = 0, no correction needed

4.2. CLT CONSTRUCTIONS WITH PAROC ZEROFIX-MOUNTING SYSTEM/ CONSTRUCTION EXAMPLE

External walls with CLT (Cross-laminated timber) construction provide the basis for optimum insulation solutions, as the entire building frame remains on the warm side of the insulation layer.

Note! There is currently no harmonized European product standard for CLT products, so the slabs can be CE marked according to European technical approval. The technical properties and the dimensioning of the CLT slabs are manufacturer specific.



- Inner surface layer
- 13 mm - Gypsum board (Protective covering: K_2 10 or K_2 30 according to local regulations)
- 90-120 mm - CLT
- 180 mm - Wind protection insulation PAROC Cortex One (K_2 30) or PAROC Tutto, fixing with the Insulation dowel SFS RP50/BS-4,8 wood (XFM 006) and PAROC Washer metal (XFW 003), taped seams.
- 36 mm – ventilation gap + PAROC ZEROfix mounting system: fire-treated PAROC ZEROfix nailing batten (XRB 001), cc600 fixed with Facade screw HECO Topix Plus Therm wood (XFS 006).
- Fire barriers if required.
- Cladding

The wall must be dimensioned for fire class R30 or R60, or if required, REI 30 and REI 60

R_w 49 dB / R_w + C 48 dB / R_w + C_{tr} 42 dB

(Internal K_2 10 protective covering (gypsum board 13 mm) is taken into account in the calculation of the airborne sound insulation value)

LOAD-BEARING STRUCTURE AND INTERNAL MATERIAL LAYERS

The air/vapor tightness of the **CLT structure** is based on carefully designed and implemented structural joints/connections as well as the airtightness of a solid wood element. Depending on the manufacturing technique of the CLT element, the edge of each timber of the board is either glued or unglued. In the edge-glued CLT, the structure can be implemented without a vapor barrier; while in the non-edge-glued CLT, the gaps between the timber remain visible, so tightness must be ensured with the vapor barrier.

It should also be kept in mind that in the CLT element, moisture is transferred in the non-glued wood joints. On the other hand, drying in the edge-glued element can again cause cracking.

Internal fire protection that may be required in CLT structures is usually made with gypsum board layers to be installed on the inner surface.

SINGLE OR TWO-LAYER INSULATION SOLUTION

In a single-layer insulation solution, the thick PAROC Cortex One / PAROC Tutto (t,tb) wind-protection insulation layer, which acts as both thermal insulation and wind protection, is installed directly on the outer surface of the CLT element. PAROC Cortex One / PAROC Tutto (t,tb) insulation is attached to the CLT with Insulation dowel SFS RP45x120/BS-4,8 wood (XFM 004) with washers before installing the nailing batten. Thanks to the product's excellent airtightness

and insulation capacity, the required energy efficiency can be achieved with a single thick layer of insulation. This speeds up installation work and reduces the number of products used on site.

If using a two-layer insulation solution, a soft PAROC eXtra insulation is first attached to the CLT element, on top of which a separate PAROC Cortex / PAROC Tutto (t,tb) wind-protection insulation layer is installed. The seams in different insulation layers shall be overlapping. With soft insulation it is recommended to use distancer under nailing batten.

Thermal insulation slabs must always be installed tightly against each other and against the load-bearing inner structure. When using Cortex-products the joints between the wind protection insulation boards, as well as the structural joints, are taped to ensure the complete wind tightness of the structure as soon as possible after the installation with PAROC Cortex tape (XST 022 and XST 021).

When using insulation product with an air permeability higher than $10 \times 10^{-6} \text{m}^3/\text{m}^2 \text{s Pa}$ (for covering) or $10 \times 10^{-6} \text{m}^3/\text{m} \text{s Pa}$ (for insulation), we recommend installing an air-tight covering for an insulation layer against the higher airflow behind the ventilation openings of the facade. This protective zone should be 0,6–1 m high, and it can be done by using a separate wind-protection wrap on top of the insulation layer or by using a row of Cortex slabs. This airtight zone protects the porous insulation layer against local forced convection in areas of air inlets and outlets.

FACADE

The facade cladding is attached to the CLT element through an insulating layer. PAROC Zerofix is an installation system in which the number of cold bridges penetrating the insulation layer is minimized. In this system, a fire-treated PAROC ZEROfix nailing batten (XRB 001) is installed on top of the insulation layer, where the facade cladding is then fixed. The nailing batten is attached to the CLT element with long facade screws (two lengths, part of the screws is mounted horizontally and the other part diagonally).

The nailing battens are installed on top of the insulation layer in 600 mm increments. The number, length, and location of the required facade screws shall be determined on the basis of the location of the building site, the wind speed, the height of the building, load-bearing construction, and the weight of the cladding material. The required dimensioning calculation can be performed with the PAROC ZEROfix dimensioning tool. At its simplest, each nailing batten needs one diagonal screw per floor and one horizontal screw per meter.

Facade cladding can be screwed directly into the nailing battens. If necessary, other nailing battens can also be used ($\geq 30 \times 100$ mm, cc600) depending on the level of requirements of the building type. With thinner battens, it is good to check, for example, that the bending of nailing batten is still in sufficient range. (More information: PAROC ZEROfix solution page and dimensioning tool)

PAROC wind-protection products can also be used as protective coverings for timber structures against external fire. These coverings give fire protection from charring 10 to 30 minutes. Fixing of protective covering shall be done according to separate instructions.

ZEROfix system in CLT:

Facade screw HECO Topix Plus Therm wood (XFS 006) length and installation depths for different insulation thicknesses:

PAROC Cortex One thickness (mm)	Length of horizontal screw (mm)	Length of diagonal screw (mm), screw angle 30°	Length of diagonal screw (mm), screw angle 45°
100	200 (64)	240 (72)	280 (62)
150	240 (54)	280 (56)	360 (69)
200	300 (64)	330 (50)	450 (82)
250	360 (74)	400 (61)	500 (68)
300	400 (64)	450 (54)	550 (53)

Insulation thickness and 36 mm PAROC ZEROfix nailing batten (XRB 001) thickness are included in screw dimensions. Installation depth for CLT is min. 48 mm.

Fire classified protective coverings K_2

PAROC Cortex One	80 - 250 mm	$K_2,30$
PAROC Cortex pro	50 - 70 mm	$K_2,30$

When using wooden facade cladding in high-rise buildings, fire breaks might be required to be used in each floor. This is good to keep in mind when dimensioning the ventilation gap. When using fire barriers, it is recommended to use PAROC Cortex products for wind protection, as fire barriers increases local convection around them.

U-values for different insulation thicknesses (CLT slab thickness 90 mm with ZEROfix mounting system)

	Insulation thickness (mm)		
PAROC Cortex One / PAROC Tento (t,tb,)	180	205	220
U-value, W/m ² K	0,17	0,15	0,14

Calculation parameters (According to EN 6946):

Gypsum board $\lambda_U = 0.25$ W/mK, d = 13/18 mm,

R = 0.052 or 0.072 m²K/W

PAROC Cortex One / PAROC Tento (t,tb,) $\lambda_U = 0.033$ W/mK

CLT slab $\lambda_U = 0.11$ W/mK, d = 90 mm

Surface resistances: $R_{si} + R_{se} = 0.26$ m²K/W

Corrections to thermal transmittance used in calculation:

ΔU_f = Correction for mechanical fasteners depending on insulation thickness, d = 180, 205 and 220 mm is over 3%, and it has been taken into account in the U-value calculations.

ΔU_g = Correction for air voids = $\Delta U''$: Level 0

4.3. METAL FRAME FACADE SYSTEMS/CONSTRUCTION EXAMPLE

The metal profile frame system can be used with all different types of load-bearing wall structures, and its use provides unlimited possibilities for the choice of different facade materials.

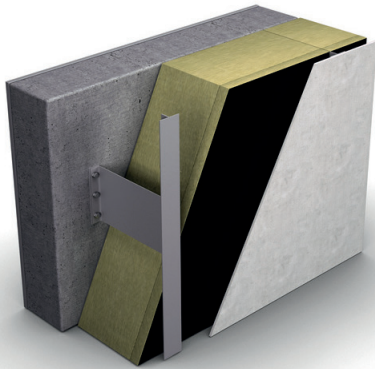

- Load bearing construction (concrete, aerated concrete, brick, etc.)
- Metal sub-construction (wall brackets with T-profiles)
- Thermal insulation
 - two-layer system: PAROC eXtra / eXtra pro + PAROC Cortex /Cortex pro PAROC Tento (t,tb) or
 - one-layer system: PAROC Cortex One / PAROC Tento (t,tb)
PAROC Cortex One seams are taped with PAROC Cortex tape (XST 022) and corners with PAROC Cortex corner tape (XST 021)
- Cladding board + e.g., render finish

Fire classification to be dimensioned R30/R60 (when required)

Sound insulation value to be calculated

FACADE SYSTEM

The facade-supporting substructure used in metal-framed facade systems is usually made of aluminum or stainless steel. The type of metal used in the system has a large effect on the required insulation thickness. This is due to the large number of wall brackets (cold bridges) penetrating the thermal insulation layer and the high thermal conductivity of the metal. Stainless steel brackets have the lowest thermal conductivity of metals brackets. There are also facade systems on the market where the thermal conductivity of the bracket has been reduced by cold bridge breaks (e.g., Hilti) or by optimizing the bracket size (e.g., Sto Ventro X). In these systems, the insulation thickness can also be kept thin. The system manufacturer designs the number and size of fasteners per square meter of wall. In general, the number of wall brackets can vary between ~2–4 pcs/m². The thicker insulation layer requires a larger support, which increases the height of the bracket and thus also the cold bridge effect. If the wall bracket is changed from one system to another, the change in the cold bridge effect of the brackets must be checked so that the U-value of the structure remains at the required level.

THERMAL INSULATION

Thermal insulation is usually installed either between the wall brackets or by notching the brackets in the insulation slab. Thermal insulation can be done with either a two-layer or single-layer insulation solution.

In a two-layer solution, a thicker soft insulation layer (eg. PAROC eXtra) is first installed tightly against the load-bearing wall structure, on top of which a thinner wind-protection insulation (eg. Cortex or WAS 25) is installed - the seams of the overlapping insulation layers overlap.

In a single-layer insulation solution, the entire thermal insulation and wind protection layer is implemented with one thick layer of wind protection insulation (e.g., PAROC Cortex One or WAS 35). The seams between the Cortex wind protection insulation slabs, as well as structural joints, are taped to ensure the total airtightness of the structure.

FACADE CLADDING

Metal profiles and facade cladding is installed shortly after insulation installation to give weather protection for the inner construction layers. Metal frame systems provide unlimited possibilities for the implementation of various facades. The most popular finishes are e.g., render, brick tile, and various building boards and combinations thereof.

Below you can find already-calculated insulation thicknesses for some metal frame systems on the market.

STO Ventro X

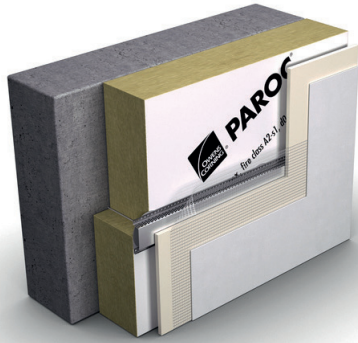

U values (one-layer insulation solution) for STO Ventro X -facade systems

	Insulation thickness (mm)	
PAROC Cortex One/ PAROC Tento	135	205
U-value, W/m ² K	0,25	0,17

Hilti Eurofox MFT – FOX VT

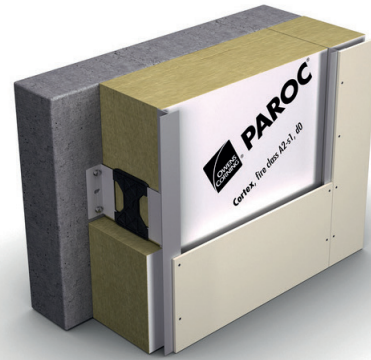

U-values (one-layer insulation solution) for Hilti Eurofox MFT-FOX VT -system

	Insulation thickness (mm)	
PAROC Cortex One/ PAROC Tento	125	185
U-value, W/m ² K	0,25	0,17

Calculation parameters (According to EN 6946):

Concrete inner core 80 mm (STO Ventro X)

$\lambda_U = 2.5 \text{ W/mK}$, $d = 80 \text{ mm}$, $R = 0.032 \text{ m}^2\text{K/W}$

Concrete inner core 150 mm (Hilti Eurofox MFT-FOX VT)

$\lambda_U = 2.5 \text{ W/mK}$, $d = 150 \text{ mm}$, $R = 0.060 \text{ m}^2\text{K/W}$

PAROC Cortex One / PAROC Tento

$\lambda_U = 0.033 \text{ W/mK}$

Surface resistances: $R_{si} + R_{se} = 0.26 \text{ m}^2\text{K/W}$

Corrections to thermal transmittance used in calculation:

ΔU_f = Correction for mechanical fasteners in STO-system: $d = 135 \text{ mm} = 0,018$, $d = 205 \text{ mm} = 0,016$ (> 3%)

ΔU_f = Correction for mechanical fasteners in Hilti-system: $d = 125 \text{ mm} = 0,0105$, $d = 185 \text{ mm} = 0,0057$ (> 3%)

ΔU_g = Correction for air voids = $\Delta U''$: Level 0 = 0

4.4. MASONRY/CONSTRUCTION EXAMPLE

The brick facade can be used with a wide range of load-bearing structures. Unlike other ventilated facade structures, the dimensioning of the ventilation gap/openings of brick facades is mainly based on the high moisture capacity of the brick cladding and its effect on other constructions. As most of the facade materials are rather thin, they tend to dry fast. Thick and porous brick facade can absorb a lot of moisture in changing weather conditions. The heavy moisture load of a facade cladding increases the drying time and moisture level in the ventilation gap. Therefore, it is important to pay attention when designing the ventilation openings for brick facade to keep the air low rate high enough and moisture level of the structure at a safe level.

Dimensioning table for ventilation gap and openings can be found from pages 7–11.



- 150 mm -Load bearing construction: concrete
- 180–220 mm -Thermal insulation:
 - One-layer insulation solution: PAROC Cortex One or PAROC Tendo (t,tb)
 - Two-layer insulation solution: PAROC eXtra + PAROC Cortex (pro) or PAROC Tendo (t,tb)
- 40 mm -Ventilation gap ≥ 30 mm for 1–2 floors, ≥ 35 –50 mm for > 2 floor buildings
- 130 mm -Brick facade, fixed to the load bearing structure with brick ties.

Fire classification to be dimensioned R30/R60 (when required)

R_w 60 dB/ R_w + C 58 dB/ R_w + C_{tr} 52 dB

STONE WALLS

The thermal insulation layer is installed on the outer surface of the stone-based, load-bearing wall. Thermal insulation can be done with either a one- or two-layer insulation solution. In a two-layer solution, a thicker soft insulation layer (e.g., Paroc eXtra) is first installed against a load-bearing wall structure, on top of which a thinner wind-protection insulation (e.g., PAROC Cortex) is installed - the joints of the insulation layers are overlapped. In a single-layer insulation solution, the thermal insulation and the required wind protection are provided with one thick layer of wind-protection insulation (e.g., PAROC Cortex One / PAROC Tendo). The seams between the Cortex- wind protection insulation boards and joining constructions are taped to ensure the airtightness of the structure.

The brick cladding is supported to the load-bearing wall structure through an insulating layer with brick ties. The effect of cold bridges formed by brick ties should be considered when calculating the U-value.

Based on VTT's research and its results, it is recommended to avoid high windowless brick-clad facade structures, as it can be difficult to ensure adequate ventilation. Utilizing the detailing of the window openings as part of the ventilation opening will greatly improve the ventilation of the brick cladding background. Thinner facade bricks or water-repellent surface treatment improve the moisture performance of the brick clad structure.

The upper part of the wooden sub-frames in brick-clad concrete apartment buildings is protected from moisture

with a breathable Tyvek fabric. A water-repellent but water vapor-permeable fabric is installed on top of the subframe. It protects the wooden structure from water during installation and allows the building moisture to dry. The transfer of moisture from a fresh concrete wall to the wooden sub-frame is prevented by a bitumen strip installed between the frame and the concrete wall.

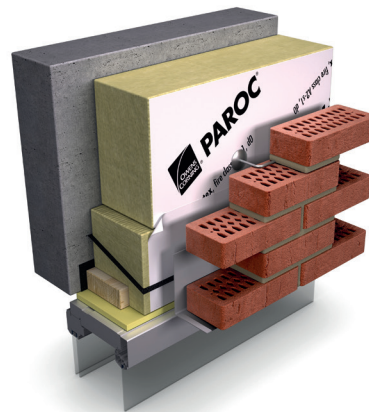

PAROC DUO L (pictured on top of the window sub-frame) is a stone wool lamella cut diagonally in the middle, between which a bitumen strip protecting the subframe from moisture can be pre-installed at the precast concrete plant. When using a bitumen strip, it should be noted that the bitumen strip cannot be installed directly on the surface of the wooden sub-frame, but sufficient space must be left between the frame and the bitumen strip that protects it to allow the wooden sub-frame to dry.

U values for different insulation thicknesses:

1-layer insulation solution

	Insulation thickness (mm)			
PAROC Cortex One / PAROC Tento	120	180	205	220
U-value, W/m ² K	0,25	0,17	0,15	0,14

In addition to the above-mentioned protection solutions, the wooden sub-frame must be insulated from the outside with a layer of wind-protection insulation that is approximately 50 mm thick. The insulation keeps the temperature of the frame higher than the outdoor temperature and thus ensures the moisture-safe operation of the wooden structure in different seasons.

2-layer insulation solution

	Insulation thickness (mm)						
PAROC Cortex One / PAROC Tento	30		30	30			
PAROC Cortex pro		40			50	55	50
PAROC eXtra, (eXtra F or Natura Lana)	100	150		175	175	175	200
PAROC eXtra pro			150				
U-value, W/m ² K	0,25	0,17	0,17	0,16	0,15	0,14	0,13

Calculation parameters (According to EN 6946):

Concrete inner core 150 mm $\lambda_U = 2.5 \text{ W/mK}$, $d = 150 \text{ mm}$, $R = 0.060 \text{ m}^2\text{K/W}$

PAROC Cortex One / PAROC Tento $\lambda_U = 0.33 \text{ W/mK}$

PAROC eXtra $\lambda_U = 0.36 \text{ W/mK}$

PAROC eXtra pro $\lambda_U = 0.33 \text{ W/mK}$

PAROC Cortex $\lambda_U = 0.33 \text{ W/mK}$

PAROC Cortex pro $\lambda_U = 0.32 \text{ W/mK}$

Surface resistances: $R_{si} + R_{se} = 0.26 \text{ m}^2\text{K/W}$

Corrections to thermal transmittance used in calculation:

ΔU_f = Correction for mechanical fasteners. Brick ties $\varnothing 4 \text{ mm}$, 4–6 psc/m², $\lambda_U = 17 \text{ W/mK}$ (< 3%)

ΔU_g = Correction for air voids = $\Delta U''$: Level 0

TIMBER WALLS

Well-ventilated brick cladding can also be used safely with wooden structures. In taller timber-framed buildings with a brick facade, it is recommended to increase the airflow of the ventilation gap by also utilizing window sills as ventilation openings.

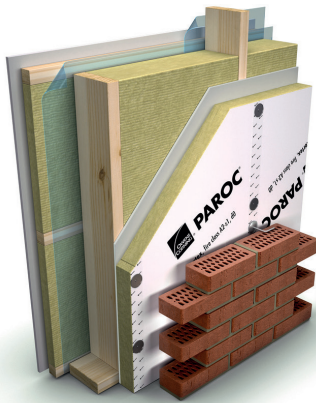

- 13 mm - plaster board
- 50 mm - studding 50 x 50 mm, cc 600 / PAROC eXtra
- 18 mm - Fire protective board for wooden structure if needed, e.g., K₂30
- Air/vapor barrier: PAROC Vapour barrier 020 (XMV 020), taped seams with PAROC Vapour barrier sealing tape (XST 013)
- 148 mm - Timber frame 48 x 148 mm C24, cc 600 / Thermal insulation 150 mm PAROC eXtra or PAROC eXtra pro
- 50 mm Wind protection insulation: PAROC Cortex pro (or PAROC Cortex), taped seams: PAROC Cortex tape (XST 022) and corners with PAROC Cortex corner tape (XST 021)
- ≥40 mm ventilation gap
- 130 mm - Brick cladding

REI 60 (EUF129-19003518-T1)

R_w 64 dB/R_w + C 63 dB/R_w + C_{tr} 58 dB

U-values for different insulation thicknesses

	Insulation thickness (mm)							
PAROC eXtra (inner structure)		50	50			50	50	50
PAROC eXtra	100	150	125	175		175	175	200
PAROC eXtra pro					150			
PAROC Cortex pro	40		40	40	50	40	55	55
PAROC Cortex or PAROC Tento		30						
U-value, W/m ² K	0,25	0,17	0,17	0,17	0,17	0,14	0,13	0,12

Calculation parameters (According to EN 6946):

Vapor barrier	$\lambda_U = 0.33 \text{ W/mK}$, $d = 0.25 \text{ mm}$ $R = 0.001 \text{ m}^2\text{K/W}$
Gypsum board	$\lambda_U = 0.25 \text{ W/mK}$, $d = 9/13 \text{ mm}$ $R = 0.036/0.052 \text{ m}^2\text{K/W}$
PAROC eXtra	$\lambda_U = 0.36 \text{ W/mK}$
PAROC eXtra pro	$\lambda_U = 0.33 \text{ W/mK}$
PAROC Cortex / PAROC Tento	$\lambda_U = 0.33 \text{ W/mK}$
PAROC Cortex pro	$\lambda_U = 0.32 \text{ W/mK}$
Timber	$\lambda_U = 0.12 \text{ W/mK}$

Surface resistances: $R_{si} + R_{se} = 0.26 \text{ m}^2\text{K/W}$

Corrections to thermal transmittance used in calculation:

Wooden frame: 50 x 50/125/150/175/200 mm, cc 600 mm

ΔU_f = Correction for mechanical fasteners < 3% = 0

ΔU_g = Correction for air voids = $\Delta U'$: Level 0

4.5. PAROC ZEROfix -MOUNTING SYSTEM/CONSTRUCTION EXAMPLES

PAROC ZEROfix is a self-supporting fastening system that is ideal for attaching the facade to the load-bearing frame through the outer insulation layer. The load-bearing frame of the building can be made of concrete or wood. When using a fastening system in connection with a timber frame wall, we recommend first installing a layer of plywood at least 15 mm thick on the outside of the frame to provide a stable base for fastening the facade. The PAROC ZEROfix system can be used in most buildings.

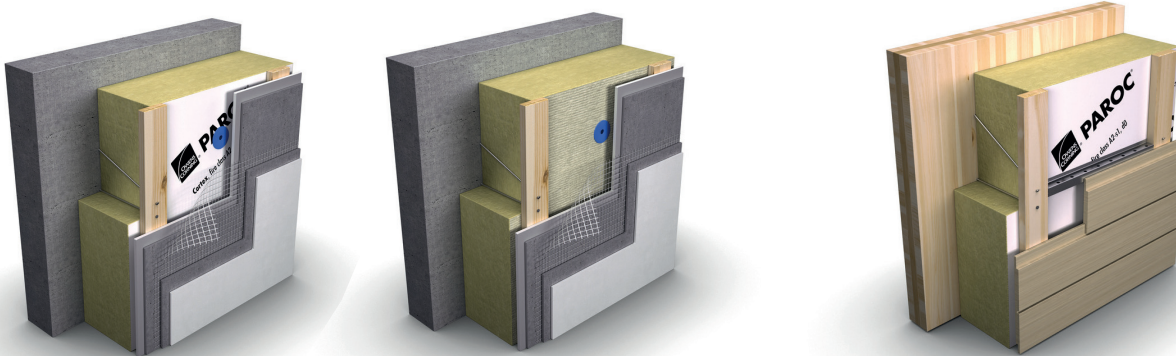

- Inner surface layer
- 150 mm – Concrete (aerated concrete or brick)
- 180 mm - Wind protection insulation PAROC Cortex One or PAROC Tento (t,tb), fixing with the Insulation dowel SFS RP50/ TI-T25-6,3 concrete (XFM 007) and PAROC Washer metal (XFW 003), Cortex products with taped seams.
- 36 mm – ventilation gap + PAROC ZEROfix mounting system: fire-treated PAROC ZEROfix nailing batten (XRB 001), cc600 fixed with Facade screw HECO Multi Monti concrete (XFS 004).
- Fire barriers in ventilation gap if required.
- Cladding (boards, rendering, or paneling)

- Inner surface layer
- 13 mm - Gypsum board (Protective covering: K₂10 or K₂30 according to local regulations)
- 90-120 mm - CLT
- 180 mm – Wind-protection insulation PAROC Cortex One (K₂30) or PAROC Tento (t,tb), fixing with the Insulation dowel SFS RP50/BS-4,8 wood (XFM 006) and PAROC Washer metal (XFW 003), Cortex -products with taped seams.
- 36 mm – ventilation gap + PAROC ZEROfix mounting system: fire-treated PAROC ZEROfix nailing batten (XRB 001, cc600 fixed with Facade screw HECO Topix Plus Therm wood (XFS 006).
- Fire barriers in ventilation gap if required.
- Cladding (boards, paneling, or rendering)

SYSTEM COMPONENTS

The system consists of a fire-retardant nailing batten and facade screws. The wind load of the facade is handled by horizontal facade screws and the vertical load by diagonally mounted facade screws. This combination of facade screws provides a very durable structure, where the number of cold bridges is minimized.

The number of facade screws, as well as the length and location of the screws, shall be determined based on the wind speed of the construction site, the height of the building, the type of load-bearing wall structure, and the weight of the cladding material. The required dimensioning calculation can be performed with the **PAROC ZEROfix-dimensioning tool**. If the strength properties of the load-bearing construction are not known, the structure should be tested by pull-out tests.

WOOD AND CONCRETE AS LOAD-BEARING STRUCTURE

Normally, three horizontal facade screws and one or two diagonally mounted facade screws per story

are used, both in wood and concrete structures. The vertical nailing batten is installed cc 600 mm. If the wind load is bigger, the number of horizontally mounted screws increases, and if the load on the facade materials is higher, the number of diagonally mounted screws increases. In concrete structures, the installation of facade screws requires a pre-drilled hole to be made.

OLD OR UNKNOWN SUBSTRUCTURES

The load-bearing capacity of the load-bearing structure must always be ensured by pull-out tests, especially in connection with renovation, as the quality and strength properties of the material may have changed over time. The number of test points depends on the building and its condition. The quantity must be large enough for the dimensioning to be carried out reliably. There should be at least 15 measuring points per facade surface, and measurements should be made on all insulated walls.

Pull-out tests must be carried out by qualified and trained personnel. The equipment used must be calibrated according to the manufacturer's

instructions. For measurement, we recommend, for example, Hydrajaws Limited, model 2000, equipped with a telescopic bridge that fits the length of the screw.

It is a good idea to use a PAROC Drill Bit concrete L 6,3 (XFD 001) with a diameter of 6.3 mm for testing. Pre-drilling must be performed to a drilling depth of more than 40 mm. Facade screw HECO Multi Monti concrete (XFS 004) is screwed directly into the base. The minimum penetration length of the threaded part of the screw is 35 mm. The test results and measurement points shall be accurately documented in the measurement report. Measurement reports and drawings must be archived on the construction site. Once the necessary tests have been performed, the length of the screws and the design loads can be calculated with our dimensioning tool. The measurement results must be taken into account when calculating the wind and vertical load design.

THERMAL INSULATION

The PAROC ZEROfix -system ensures excellent energy efficiency, as the entire insulation layer with seals can be installed before installing the facade system fasteners. First the thick wind protection insulation layer, PAROC Tendo (t,tb) or PAROC Cortex One is installed on the outer surface of the load-bearing structure, a nailing batten is installed on top of the rigid insulation layer with horizontal screws according to the dimensioning program instructions. Finally, the diagonal screws are added at the specified distances.

The porous insulation slabs and the breathable coating in Cortex-products do not prevent the building moisture from drying out. The wind tightness of the building envelope is ensured by taping the Cortex seams and cutting surfaces to the associated structures.

There must always be a ventilation gap behind the facade cladding. The use of wood cladding on the facade may require the installation of fire barriers in the ventilation gap. This is a good thing to keep in mind when dimensioning the ventilation opening and choosing the wind protection insulation. We recommend the use of PAROC Cortex products in constructions with fire barriers, as obstacles in the ventilation gap increase local convection around them.

The nailing batten serves as a mounting base for the selected facade cladding. The facade cladding is installed on the nailing batten according to the facade supplier's instructions.

PAROC wind protection insulation products can be used as a fire protective covering for a wooden construction against external fire. These products provide fire protection of the frame from charring for 10–30 minutes.

Fire classified protective coverings K₂

PAROC Cortex One	180 mm	K ₂ 30
PAROC Cortex	50 mm	K ₂ 30

U-values for different insulation thicknesses with different load-bearing constructions:

Load-bearing construction/Concrete 150 mm

	Insulation thickness (mm)							
PAROC Cortex One / PAROC Tendo (t,tb)	100	135	150	180	200	220	250	300
U-value, W/m ² K	0,33	0,24	0,23	0,19	0,17	0,15	0,14	0,12

Load-bearing construction/CLT-slab 100 mm

	Insulation thickness (mm)		
PAROC Cortex One / PAROC Tendo (t,tb)	180	205	220
U-value, W/m ² K	0,16	0,14	0,13

Calculation parameters (According to EN 6946):

Gypsum board $\lambda_U = 0.25$ W/mK, d = 18 mm, R = 0.072 m²K/W

PAROC Cortex One / PAROC Tendo (t, tb) $\lambda_U = 0.33$ W/mK

PAROC XFS 002 -facade screw $\lambda = 50$

- Horizontal screws: cc 600/1200
- Diagonal screws (30°): cc 600/2700
- Nailing battens cc 600

Concrete inner core 150 mm $\lambda_U = 2.5$ W/mK, d = 150 mm, R = 0.060 m²K/W

Aerated concrete 250 mm $\lambda_U = 0.14$ W/mK, d = 250 mm

CLT-slab $\lambda_U = 0.11$ W/mK, d = 100 mm

Surface resistances: $R_{si} + R_{se} = 0.26$ m²K/W

Corrections to thermal transmittance used in calculation:

- ΔU_g = Correction for air voids = $\Delta U''$: Level 0
- ΔU_f (ZEROfix/CLT) = with insulation thicknesses 180, 205, and 220 mm, the cold-bridge effect of mechanical fastener > 3%, and it has been taken into account in the U-value calculation (0,009–0,011 W/m²K)
- ΔU_f (ZEROfix/concrete) = with insulation thicknesses 135, 180, 205, and 220 mm, the cold-bridge effect of mechanical fastener > 3%, and it has been taken into account in the U-value calculation (0,012–0,018 W/m²K) (Sweden red 0,011–0,029W/m²K)

COMPONENTS OF PAROC ZEROfix -FACADE SYSTEM



PAROC Cortex One -wind-protection insulation /
PAROC Tento (t,tb) – wind-protection insulation



PAROC ZEROfix nailing batten (XRB 001)
-fire-treated nailing batten



PAROC Cortex tape (XST 022) -tape for joints
(Cortex-products)



PAROC Cortex corner tape (XST 021)
-tape for corners (Cortex -products)



Insulation dowel SFS RP50/BS-4,8
wood (XFM 006) – distancer / fastener.
Same product works as a fastener for
the insulation as well as a distancer for
180-mm thick wind-protection insulation.



Facade screw HECO Topix Plus Therm
wood (XFS 006) – facade screw for wood

Facade screw HECO Multi Monti concrete
(XFS 004) – facade screw for concrete



PAROC ZEROfix angle tool (XTI 001)
-installation corner (30° ja 45°)

Length of screws/ZEROfix system in CLT:

Facade screws HECO Topix Plus Therm wood (XFS 006) length and their installation depths for different insulation thicknesses:

PAROC Cortex One thickness (mm)	Length of horizontal screw (mm)	Length of diagonal screw (mm), screw angle 30°	Length of diagonal screw (mm), screw angle 45°
100	200 (70)	240 (59)	280 (51)
150	240 (50)	280 (57)	360 (52)
200	300 (50)	330 (66)	450 (63)
250	360 (55)	400 (67)	500 (66)
300	400 (70)	450 (52)	550 (51)

Insulation thickness and 36 mm PAROC ZEROfix nailing batten (XRB 001) thickness are included in screw dimensions.
Installation depth for CLT is a minimum of 48 mm.

Length of screws/ZEROfix system in concrete:

Facade screw HECO Multi Monti concrete (XFS 004) length and installation depth for different insulation thicknesses:

PAROC Cortex One thickness (mm)	Length of horizontal screw (mm)	Length of diagonal screw (mm), screw angle 20°
100	200 (64)	200 (52)
120	200 (44)	250 (79)
180	300 (84)	300 (66)
205	300 (59)	300 (41)
220	300 (44)	350 (73)

Insulation thickness and 36 mm PAROC ZEROfix nailing batten (XRB 001) thickness are included in screw dimensions.
The minimum penetration length of the threaded part of the screw is 35 mm.



PAROC® stands for energy-efficient and fire resilient insulation solutions of stone wool for new and renovated buildings, HVAC and industrial applications. Behind the products, there is nearly 90-year history of stone wool production and know-how backed by technical expertise and innovation.

Going under the product name PAROC and in the instantly recognizable red-and-white-striped packages, our products include building insulations for thermal, fire and sound insulation of exterior walls, roofs, intermediate floors and partitions as well as technical insulations for HVAC systems, industrial processes and OEM industry.

*For more information, please visit **www.paroc.com***

Technical information contained herein is furnished without charge or obligation and is given and accepted at recipient's sole risk. Because conditions of use may vary and are beyond our control, Paroc makes no representation about, and is not responsible or liable for the accuracy or reliability of data associated with particular uses of any product described herein. Paroc reserves the right to modify this document without prior notice. PAROC is a registered trademark of Paroc Group Oy.

September 2024
2098BIEN0924
© PAROC 2024

